

- Ⓛ Montageanleitung
- Ⓝ Handleiding voor de montage
- Ⓣ Montaj talimati
- ⓕ Notice de montage
- Ⓒ Montážní návod
- ⓗ Szerelési útmutató
- ⓖ Assembly instructions
- Ⓟ Instrukcja montażu
- Ⓡ Инструкция по монтажу
- Ⓜ Istruzioni di montaggio
- Ⓢ Návod na montáž
- Ⓡ Instrucțiuni de montaj
- ⓔ Instrucciones de montaje
- Ⓣ Montaj Talimati

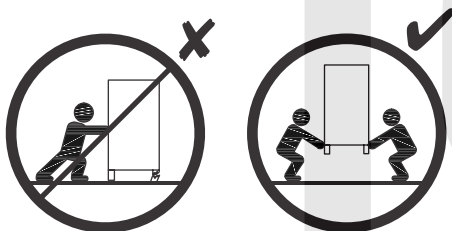

2022-02-22

3 h		

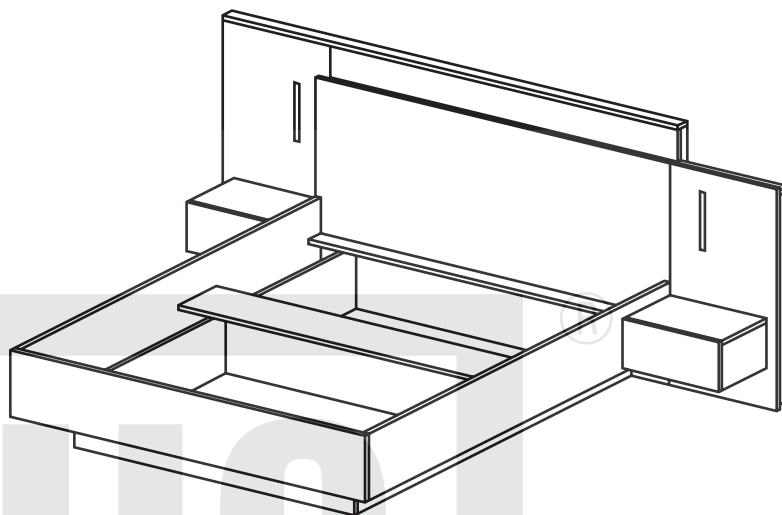

A 7 x 50 mm x 20	B 8 x 32 mm x 85	E2 3 x 20 mm x 68	E5 4 x 16 mm x 32	EE2 x 10	G2 x 19	K L=250 mm x 2	O1 x 10
O2 x 2	QA x 10	R H=11 mm x 58	R1 H=15 mm x 4	RA x 4	RB x 8	RRA H=16 mm x 4	RRB 6 x 55 x 8
RRC H=13 mm x 4	T3 5 x 9 mm x 12	U L=24,3 mm x 52	U6 L=54 mm x 5	W9 x 4	XA x 1	ZR Ø 15 x 62	
LED x 1							

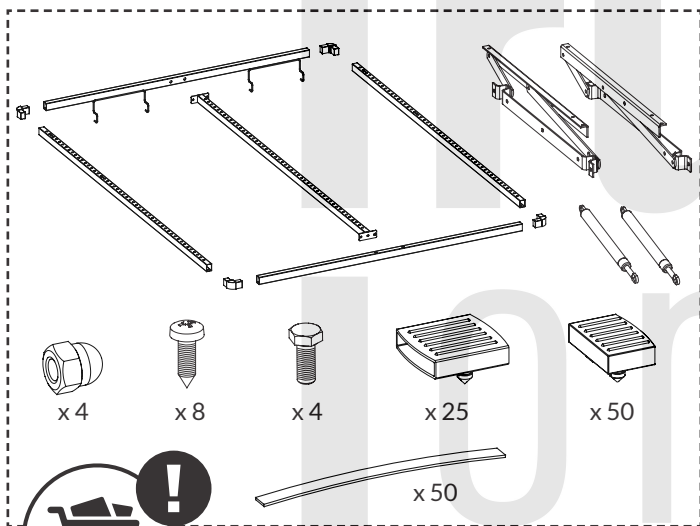

D - Die Struktur des Bettes ist an die vom Hersteller empfohlene Montage eines Metallrahmens mit Gaslift angepasst. Der Hersteller haftet nicht für Schäden oder Gesundheitsschäden, die durch die Verwendung eines anderen als des empfohlenen Rahmens verursacht werden.

NL - De structuur van het bed is aangepast aan de montage, aanbevolen door de fabrikant, een metalen frame met een gasveer. De fabrikant is niet verantwoordelijk voor schade of gezondheidsschade veroorzaakt door het gebruik van een ander frame dan aanbevolen.

TR - Yatağın yapısı, üretici tarafından önerilen, gaz asansörlü metal bir çerçeveye montajına uyarlanmıştır. Üretici, tavsiye edilenden farklı bir çerçeve kullanılabileceğinden dolayı hasar veya sağlık zararlarından sorumlu değildir.

F - La structure du lit est adaptée au montage, recommandé par le fabricant, d'une ossature métallique avec un vérin à gaz. Le fabricant n'est pas responsable des dommages ou des préjudices à la santé causés par l'utilisation d'un cadre différent de celui recommandé.

CZ - Konstrukce postele je přizpůsobena montáži, kterou doporučuje výrobce, kovový rám s plynovým výtahem. Výrobce neodpovídá za poškození nebo újmu na zdraví způsobenou použitím jiného rámu, než je doporučeno.

HU - Az ágy szerkezetét a gyártó által ajánlott összeszereléshez alakították ki, fémkeret gázemelővel. A gyártó nem vállal felelősséget az ajánlottól eltérő váz használatával okozott károkért vagy egészségkárosodásért.

GB - The structure of the bed is adapted to assembly, recommended by the manufacturer, a metal frame with a gas lift. The manufacturer is not responsible for damage or health detriment caused by using a different frame than recommended.

PL - Konstrukcja łóżka dostosowana jest do zamontowania, zalecanego przez producenta, stelaża metalowego z podnośnikiem gazowym. Producent nie ponosi odpowiedzialności za uszkodzenia czy uszczerbek na zdrowiu spowodowane wykorzystaniem innego stelaża niż zaleca.

RU - Конструкция кровати адаптирована к сборке, рекомендованной производителем, металлического каркаса с газлифтом. Производитель не несет ответственности за ущерб или вред здоровью, вызванный использованием рамы, отличной от рекомендованной.

IT - La struttura del letto è adatta al montaggio, consigliato dal produttore, di un telaio metallico con alzata a gas. Il produttore non è responsabile per danni o danni alla salute causati dall'utilizzo di un telaio diverso da quello consigliato.

SK - Konštrukcia postele je prispôbená na montáž, ktorú odporúča výrobca, kovový rám s plynovým výťahom. Výrobca nezodpovedá za škody alebo poškodenie zdravia spôsobené použitím iného rámu, ako je odporúčaný.

RO - Structura patului este adaptată asamblării, recomandată de producător, a unui cadru metalic cu ridicător pe gaz. Producătorul nu este responsabil pentru daunele sau daunele pentru sănătate cauzate de utilizarea unui cadru diferit de cel recomandat.

ES - Voodi struktura on kohandatud monteerimiseks, tootja soovitusel, gaasitõstukiga metallraam. Tootja ei vastuta kahjustuste või tervisekahjustuste eest, mis on põhjustatud soovitatud raami kasutamisest.

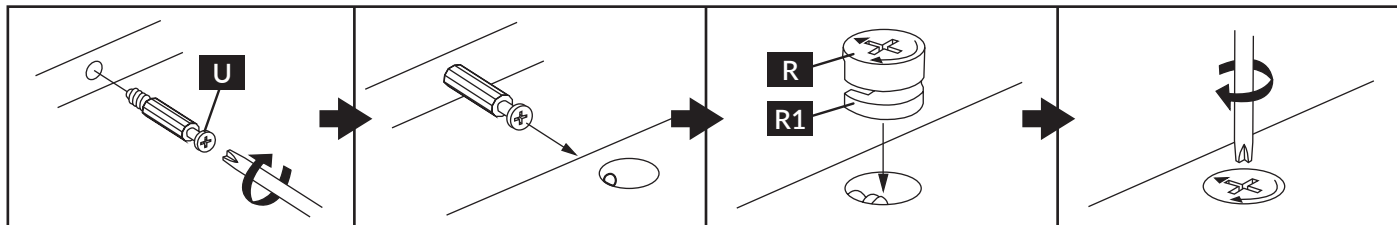
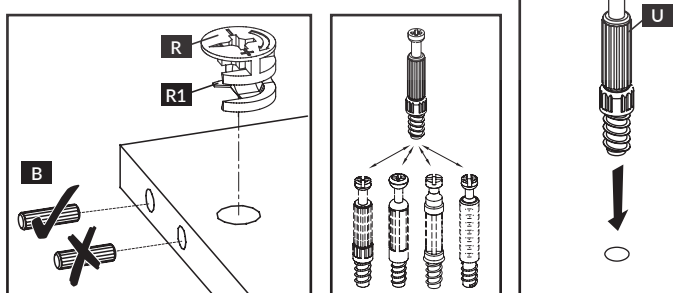
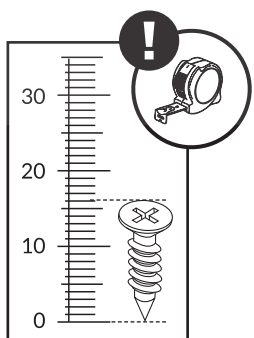

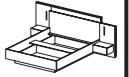

nr	↔ [mm]	↓ [mm]	∅ [mm]	Menge	Colli
I-1	900	1644	16	x 1	1/2
I-2	2112	100	16	x 1	2/2
I-3	852	100	16	x 1	1/2
I-4	852	100	16	x 1	2/2
I-5	852	100	16	x 2	1/2
I-6	1000	44	16	x 1	2/2
I-7	1000	44	16	x 1	2/2
I-8	132	1612	16	x 1	2/2
I-9	2112	60	16	x 1	2/2
I-10	1000	500	16	x 1	1/2
I-11	900	500	16	x 1	1/2
I-12	418	300	16	x 1	1/2
I-13	450	300	16	x 2	2/2
I-14	184	300	16	x 1	2/2
I-15	184	300	16	x 1	2/2
I-16	184	300	16	x 1	2/2
I-17	184	300	16	x 1	2/2

nr	↔ [mm]	↓ [mm]	∅ [mm]	Menge	Colli
I-18	1600	80	16	x 1	1/2
I-19	1600	250	16	x 1	1/2
I-20	1600	250	16	x 1	1/2
I-21	1645	272	22	x 1	2/2
I-22	2022	270	22	x 1	2/2
I-23	2022	270	22	x 1	2/2
I-24	1301	250	16	x 1	1/2
I-25	1268	250	16	x 1	1/2
I-26	1850	250	16	x 1	2/2
I-27	1850	250	16	x 1	2/2
I-28	1296	1002	3	x 1	1/2
I-29	446	196	16	x 2	1/2
I-30	361	120	16	x 2	2/2
I-31	250	120	16	x 2	2/2
I-32	250	120	16	x 2	2/2
I-33	392	256	3	x 2	1/2

D - Vor Beginn der Möbelmontage sollten alle Elemente auf Beschädigungen überprüft werden. Wenn ein Element des Produkts beschädigt ist, installieren Sie das Produkt bitte nicht und reichen Sie eine Beschwerde ein. Die Installation des Produkts auf der Grundlage der beschädigten Elemente bedeutet, dass der Käufer seinen Zustand akzeptiert, was bedeutet, dass die Beschwerde über beschädigte Elemente nicht akzeptiert wird.

NL - Voordat u met de meubelmontage begint, moeten alle elementen op schade worden gecontroleerd. Als een onderdeel van het product beschadigd is, installeer het dan niet en dien een klacht in. Installatie van het product op basis van de beschadigde elementen betekent dat de koper hun staat accepteert, wat betekent dat de claim voor beschadigde elementen niet wordt geaccepteerd.

TR - Mobilya montajına başlamadan önce tüm elemanlarda hasar olup olmadığını kontrol edilmelidir. Ürünün herhangi bir parçası hasar görmüşse, lütfen ürünü kurmayın ve şikayetle bulunun. Ürünün hasarlı elemanlar bazında montajı, Alıcının durumunu kabul ettiği anlamına gelir, bu da hasarlı elemanlar için talep kabul edilemeyeceği anlamına gelir.

F - Avant de commencer l'assemblage du meuble, tous les éléments doivent être vérifiés pour détecter tout dommage. Si un élément du produit est endommagé, veuillez ne pas installer le produit et déposer une plainte. L'installation du produit sur la base des éléments endommagés signifie que l'acheteur accepte leur état, ce qui signifie que la réclamation d'éléments endommagés ne sera pas acceptée.

CZ - Před zahájením montáže nábytku je třeba zkontrolovat poškození všech prvků. Pokud je některý prvek produktu poškozen, zdržte se instalace produktu a podejte sižnost. Instalace výrobku na základě poškozených prvků znamená, že kupující akceptuje jejich stav, což znamená, že reklamace poškozených prvků nebude uznána.

HU - A bűtorszerelés megkezdése előtt ellenőrizni kell az összes elem sérülését. Ha a termék bármely eleme megsérült, kérjük, tartózkodjon a termék telepítésétől és nyújtson be panaszt. A termék sérült elemek alapján történő felszerelés azt jelenti, hogy a Vevő elfogadja azok állapotát, ami azt jelenti, hogy a sérült elemek igényét nem fogadják el.

GB - Before starting the furniture assembly, all elements should be checked for damage. If any element of the product is damaged, please refrain from installing the product and file a complaint. Installation of the product on the basis of the damaged elements means the Buyer's acceptance of their condition, which means that the complaint of damaged elements will not be accepted.

PL - Przed rozpoczęciem montażu mebla wszystkie elementy należy sprawdzić czy nie są uszkodzone. W przypadku wykrycia uszkodzenia elementu należy odstąpić od montażu mebla i złożyć reklamację. Montaż produktu w oparciu o uszkodzone elementy oznacza akceptację ich stanu przez Kupującego, co powoduje, że reklamacja uszkodzonych elementów nie będzie uznawana.

RU - Перед началом сборки мебели следует проверить все элементы на предмет повреждений. Если какой-либо элемент продукта поврежден, пожалуйста, воздержитесь от установки продукта и подайте жалобу. Установка товара на поврежденные элементы означает, что Покупатель принимает их состояние, а значит, претензии по поврежденным элементам не принимаются.

IT - Prima di iniziare l'assemblaggio del mobile, tutti gli elementi dovrebbero essere controllati per danni. Se qualche elemento del prodotto è danneggiato, astenersi dall'installare il prodotto e presentare un reclamo. L'installazione del prodotto sulla base degli elementi danneggiati implica l'accettazione da parte dell'Acquirente della loro condizione, il che significa che il reclamo per elementi danneggiati non sarà accettato.

SK - Pred začatím montáže nábytku by sa mali skontrolovať všetky prvky, či nie sú poškodené. Ak je niektorý prvok výrobku poškodený, neinstalujte výrobok a reklamujte ho. Inštalácia produktu na základe poškodených prvkov znamená, že Kupujúci akceptuje ich stav, čo znamená, že reklamácia poškodených prvkov nebude akceptovaná.

RO - Înainte de a începe asamblarea mobilierului, toate elementele trebuie verificate pentru a nu se deteriora. Dacă vreun element al produsului este deteriorat, vă rugăm să vă abțineți de la instalarea produsului și să depuneți o reclamație. Instalarea produsului pe baza elementelor deteriorate înseamnă acceptarea de către Cumpărător a stării lor, ceea ce înseamnă că reclamația privind elementele deteriorate nu va fi acceptată.

ES - Antes de comenzar el montaje de los muebles, todos los elementos deben comprarse en busca de daños. Si algún elemento del producto está dañado, absténgase de instalar el producto y presente una queja. La instalación del producto sobre la base de los elementos dañados supone la aceptación por parte del Comprador de su estado, por lo que no se aceptará la reclamación de elementos dañados.

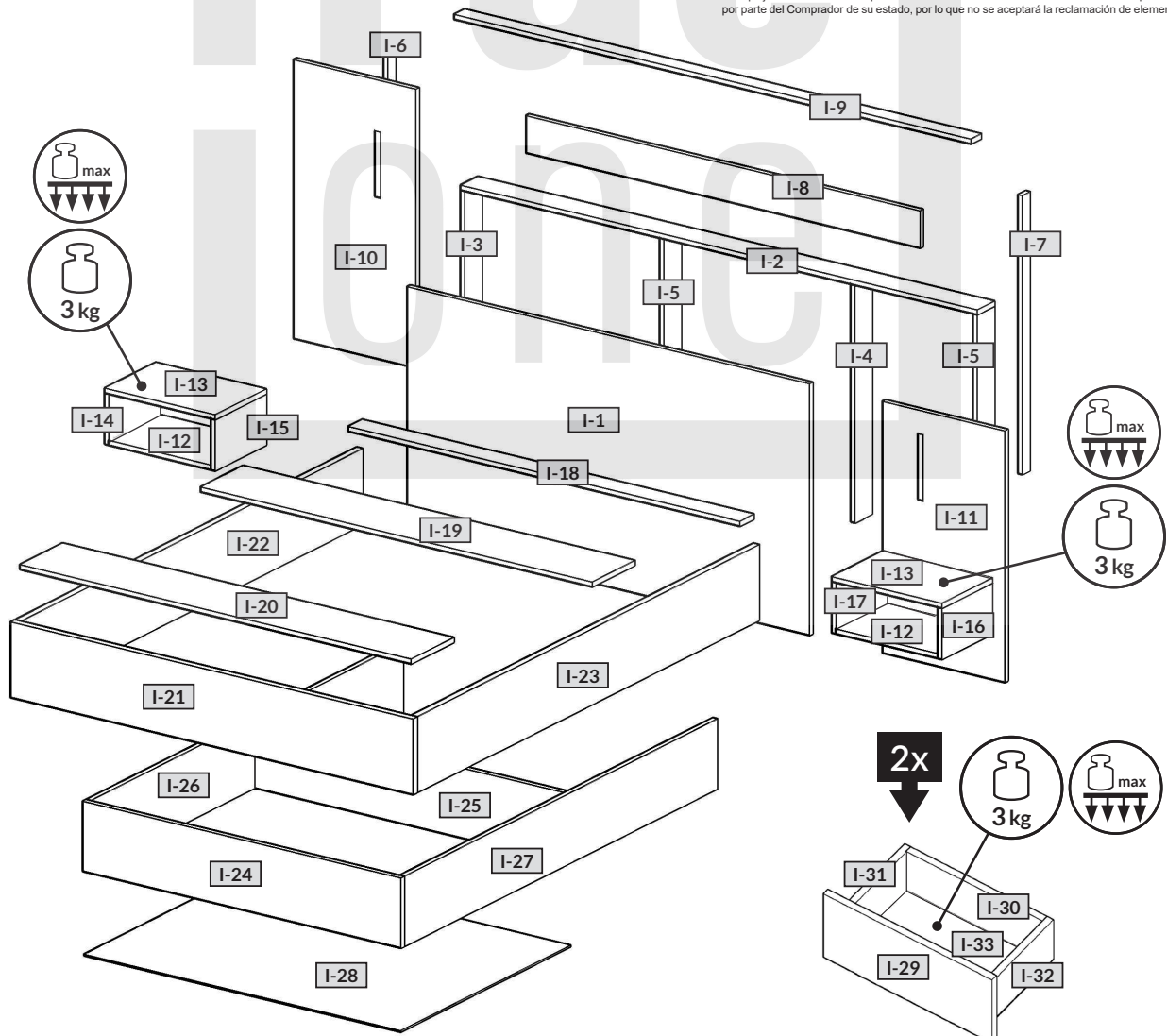

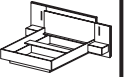

1

B 8 x 32 mm x 12

R H=11 mm x 6

U L=24,3 mm x 6

I-21

I-19

I-20

R

B

U

R

B

R

B

R

B

U

U

2

B 8 x 32 mm x 8

E5 4 x 16 mm x 16

R1 H=15 mm x 4

RRA H=16 mm x 4

U L=24,3 mm x 4

W9 x 4

I-22

I-23

RRA

B

U

W9

W9

U

W9

R1

W9

B

R1

B

RRA

W9

E5

R1

W9

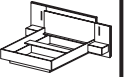

3

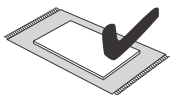
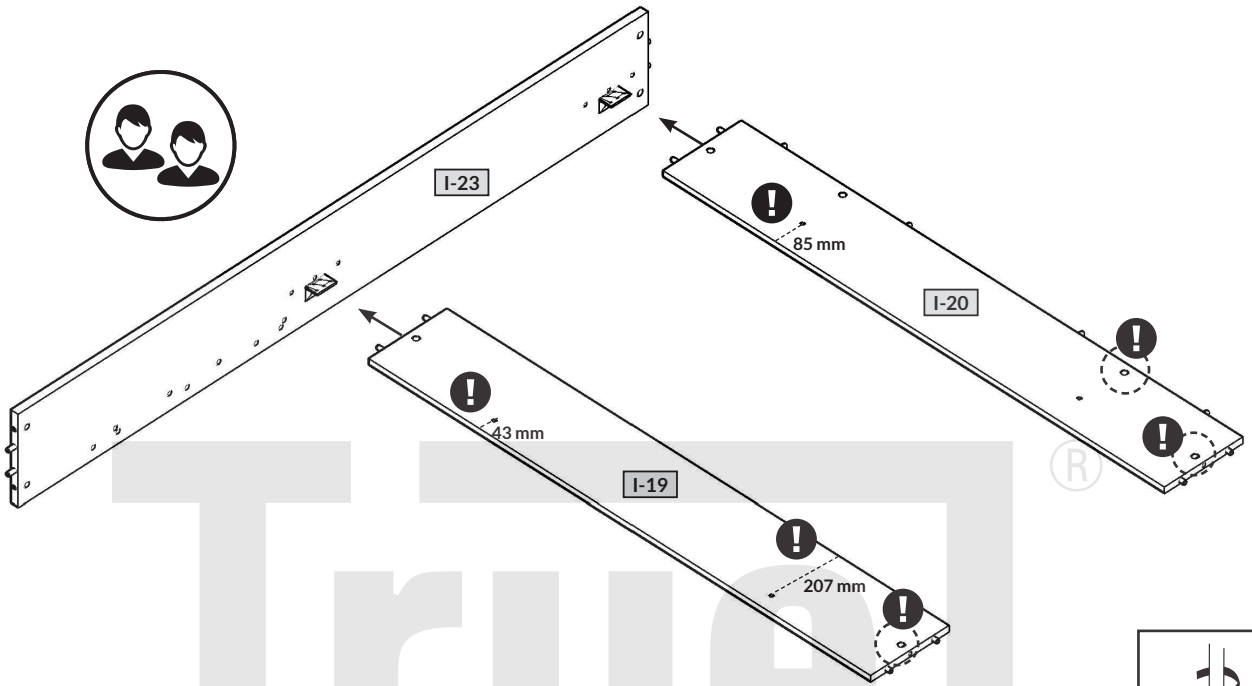

4

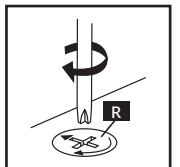
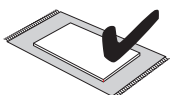
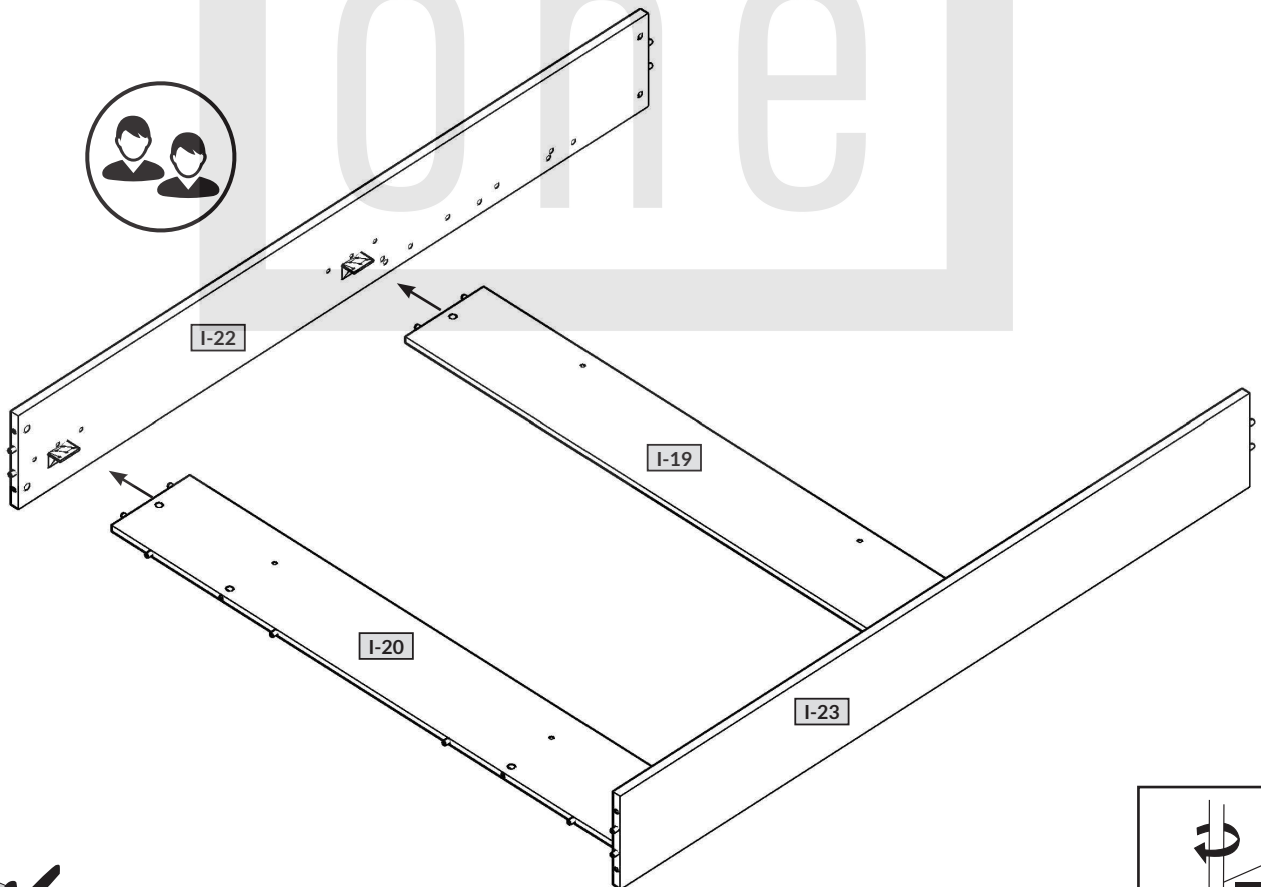

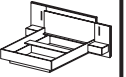

5

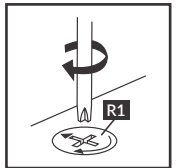
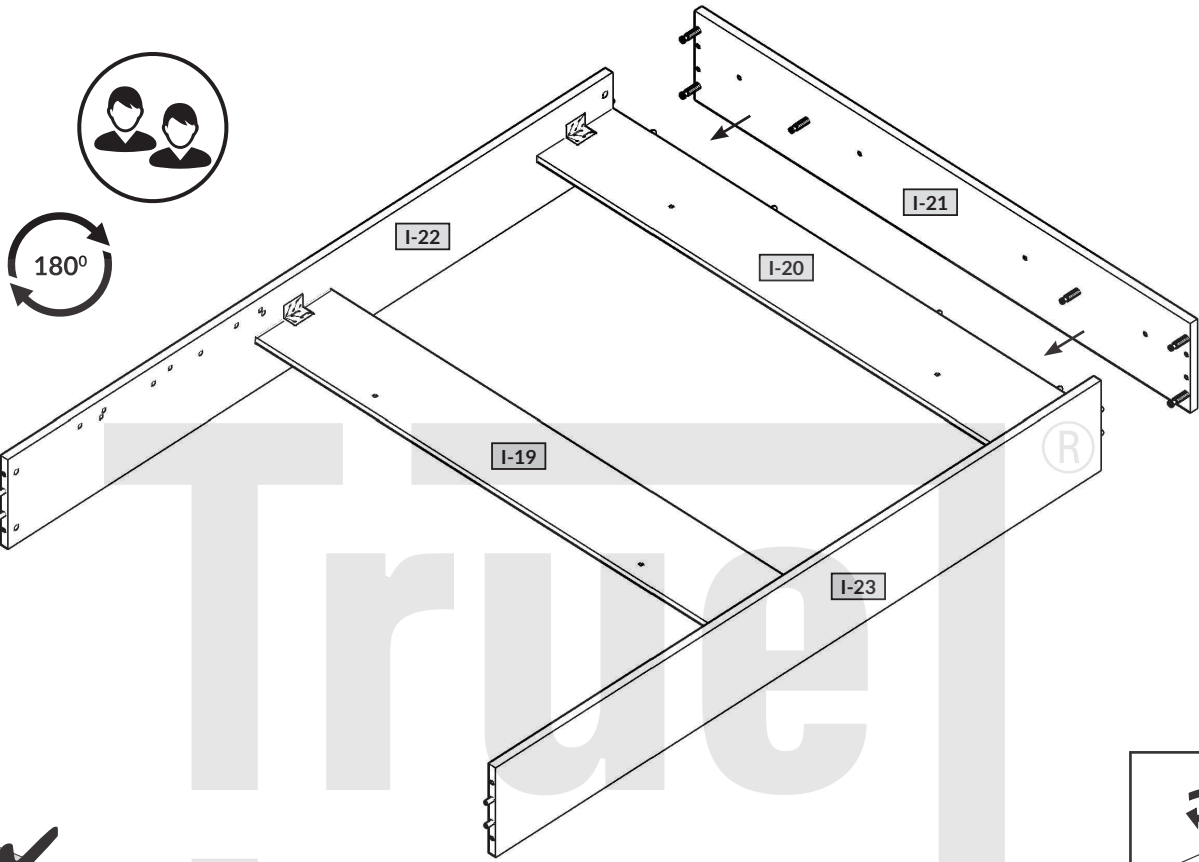

6

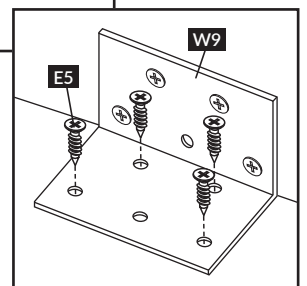
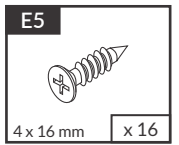
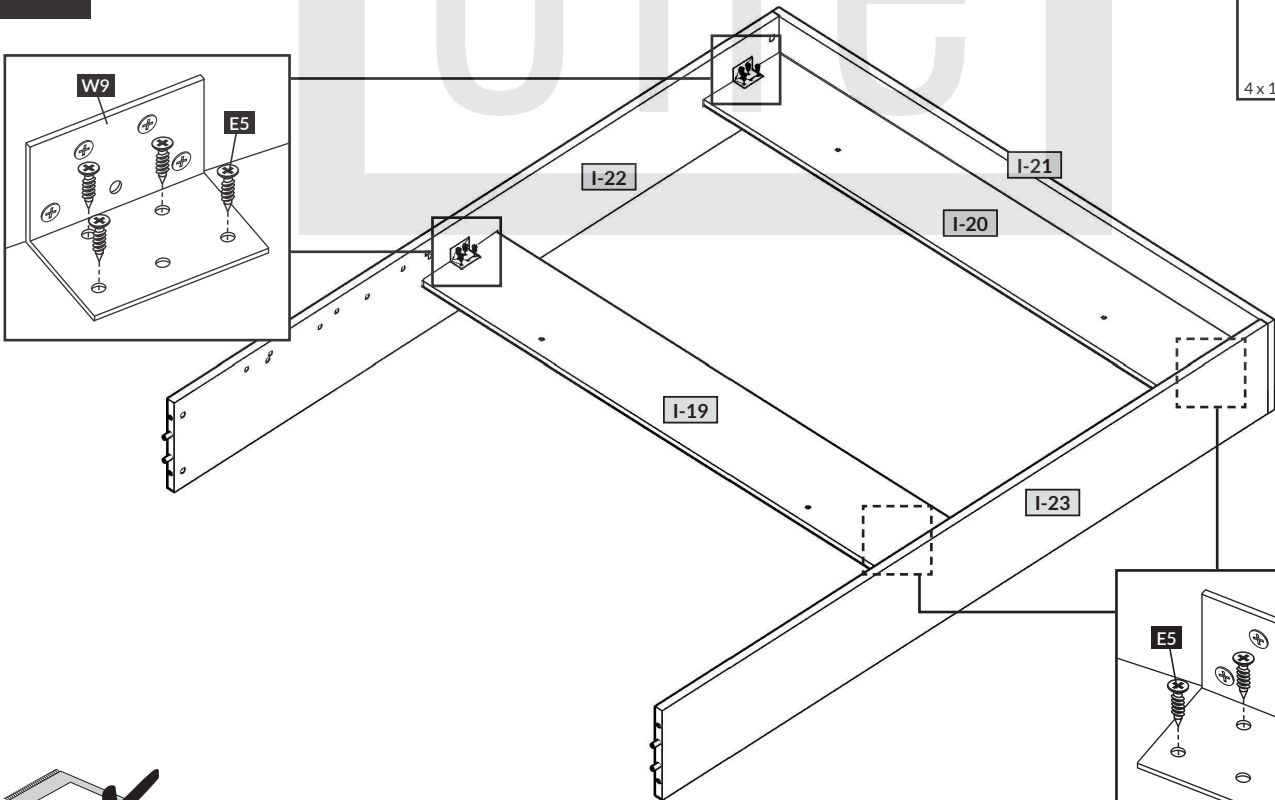

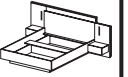

7

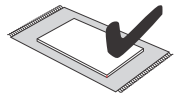
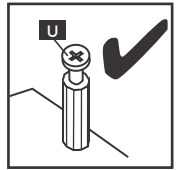
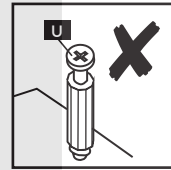
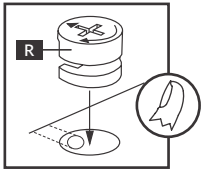
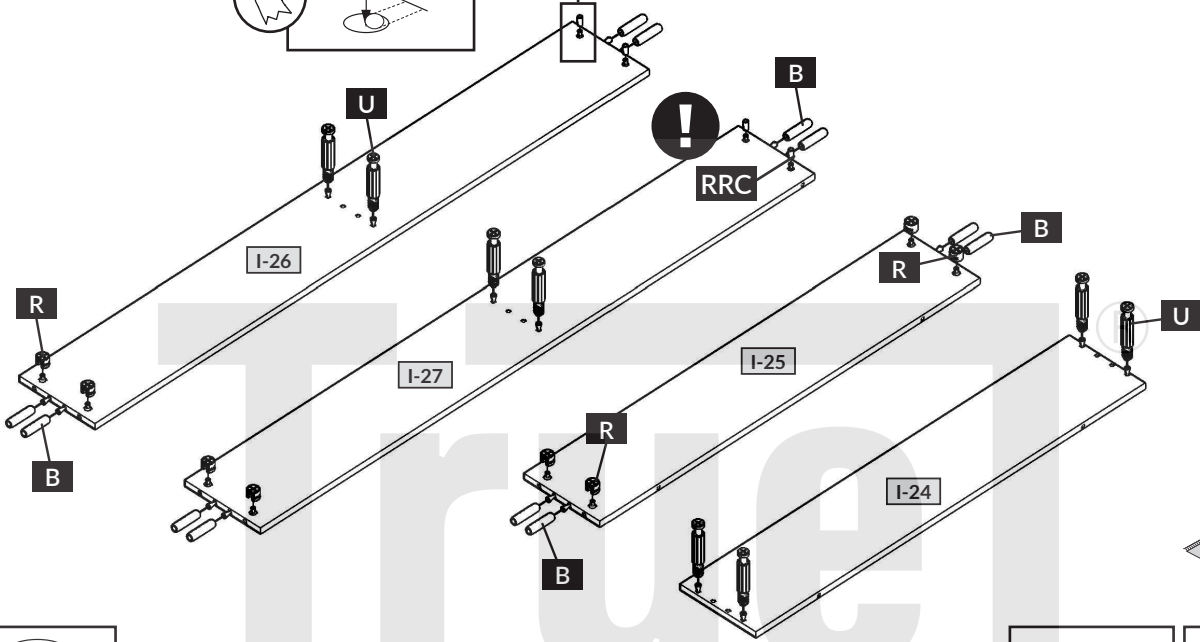
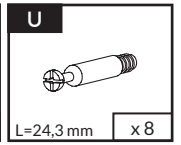
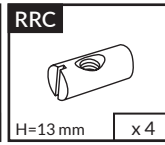
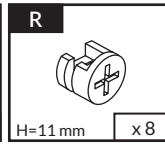
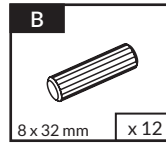
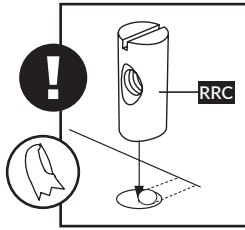

8

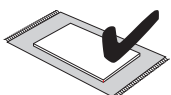
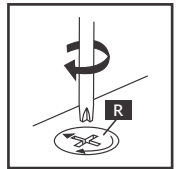
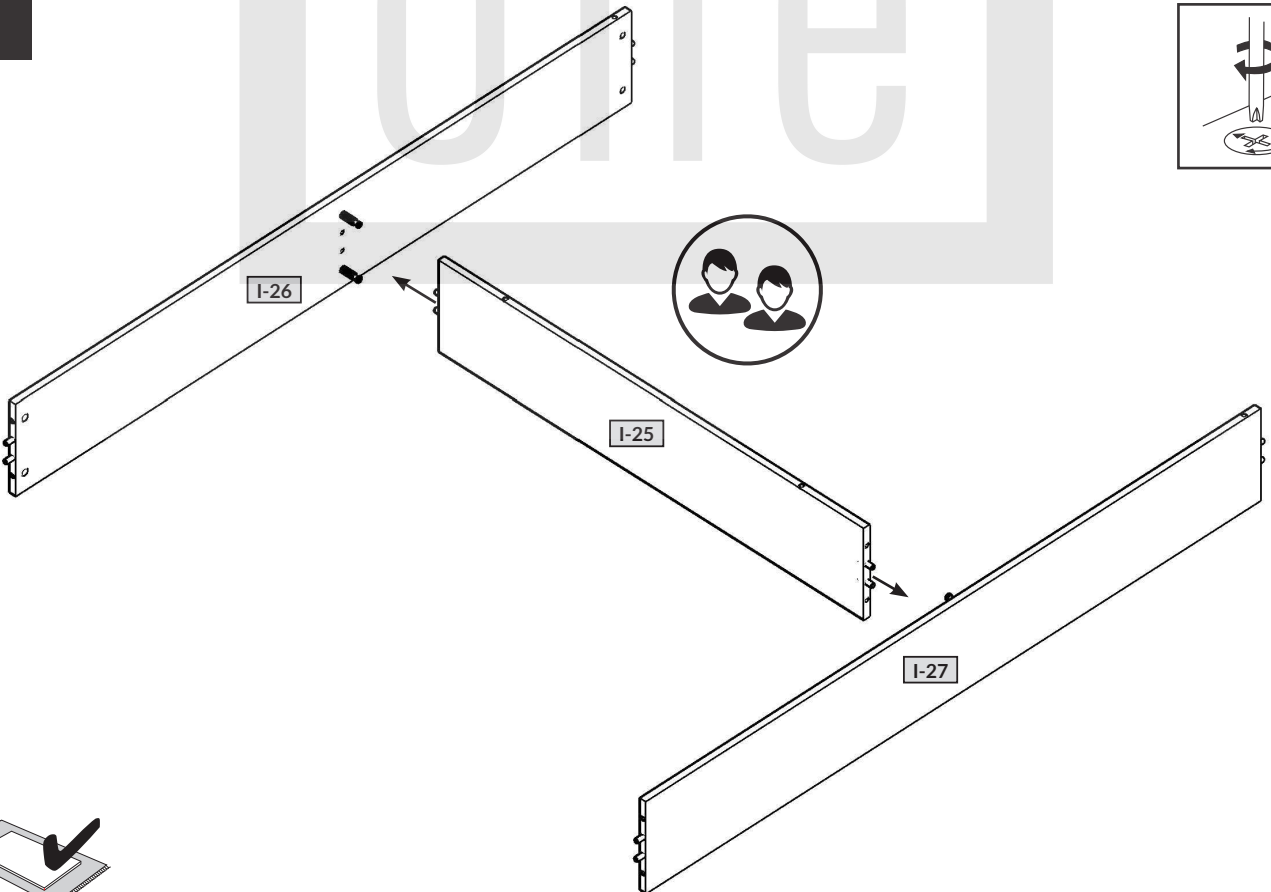

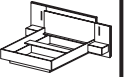

9

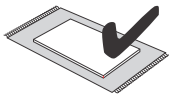
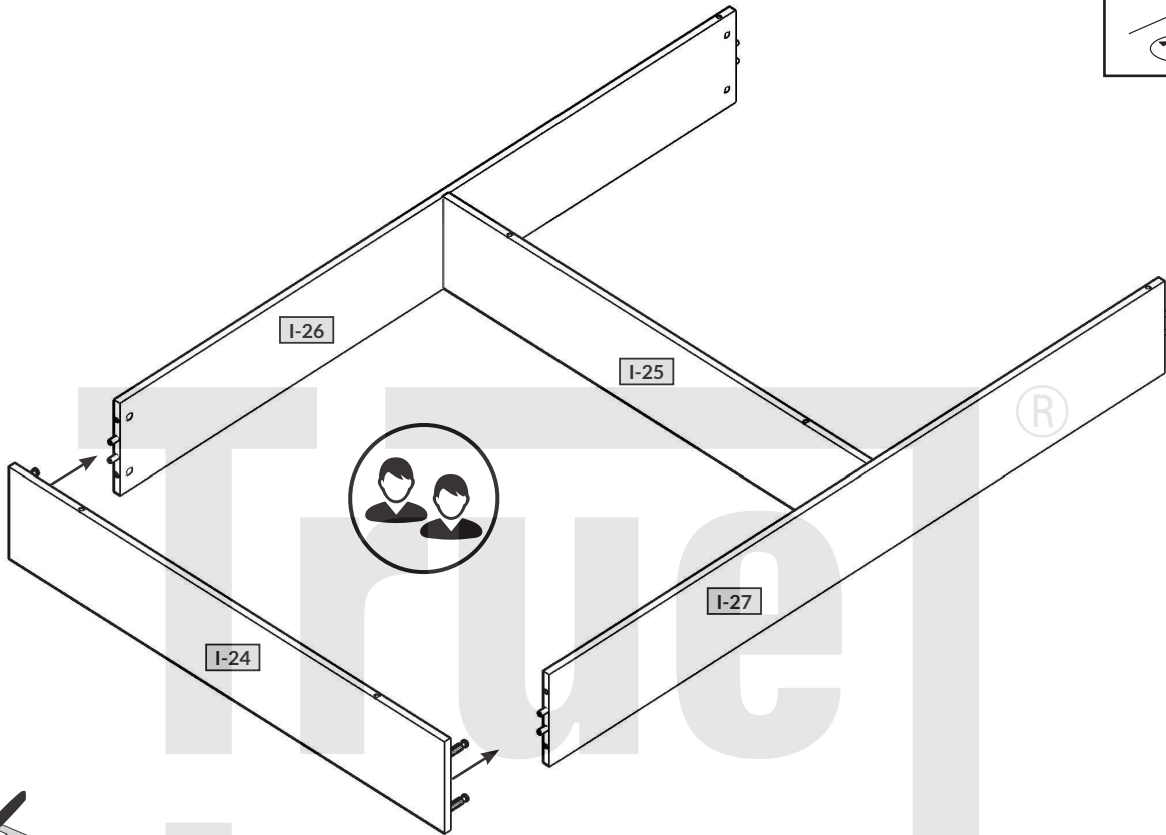

10

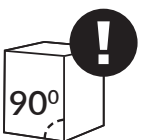
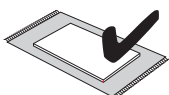
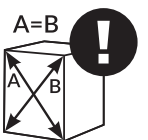
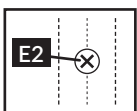
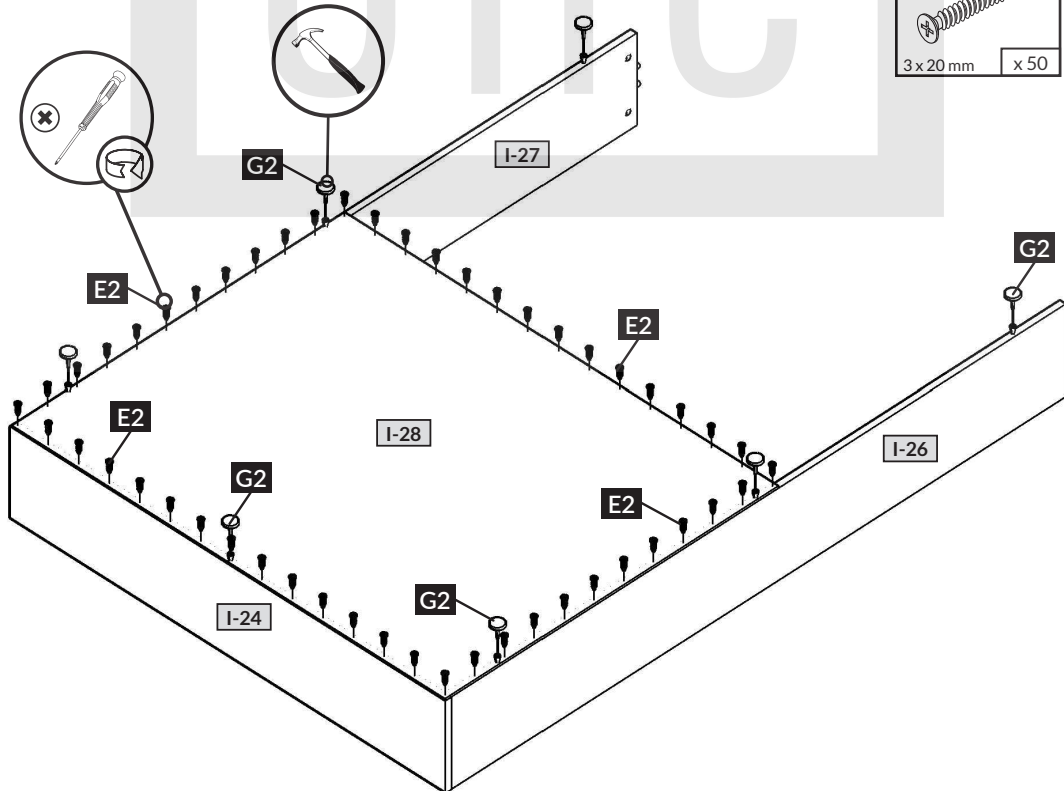
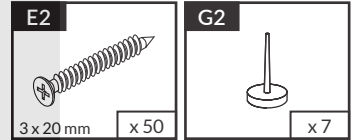

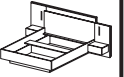

11

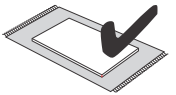
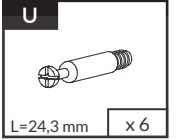
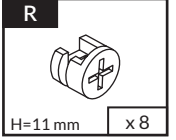
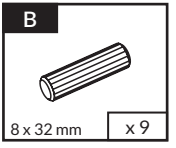
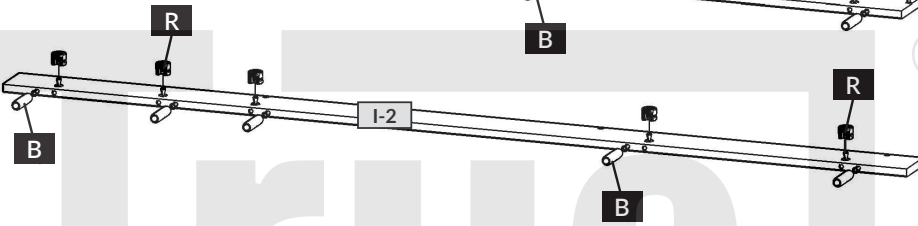
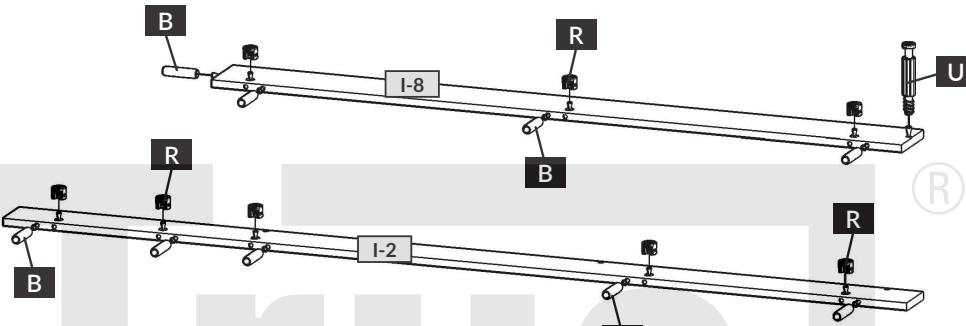
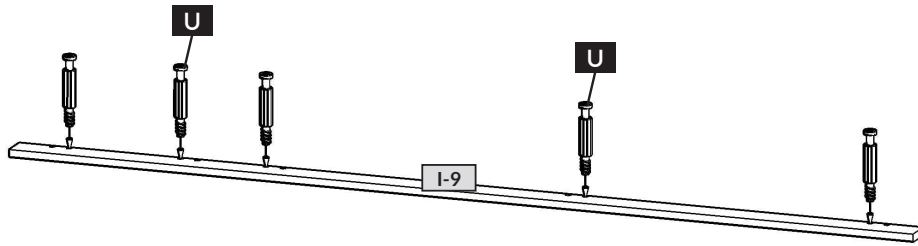
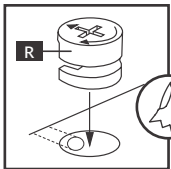
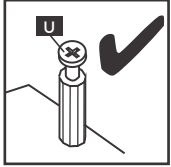

12

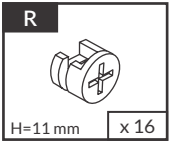
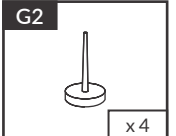
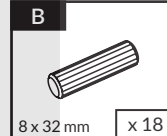
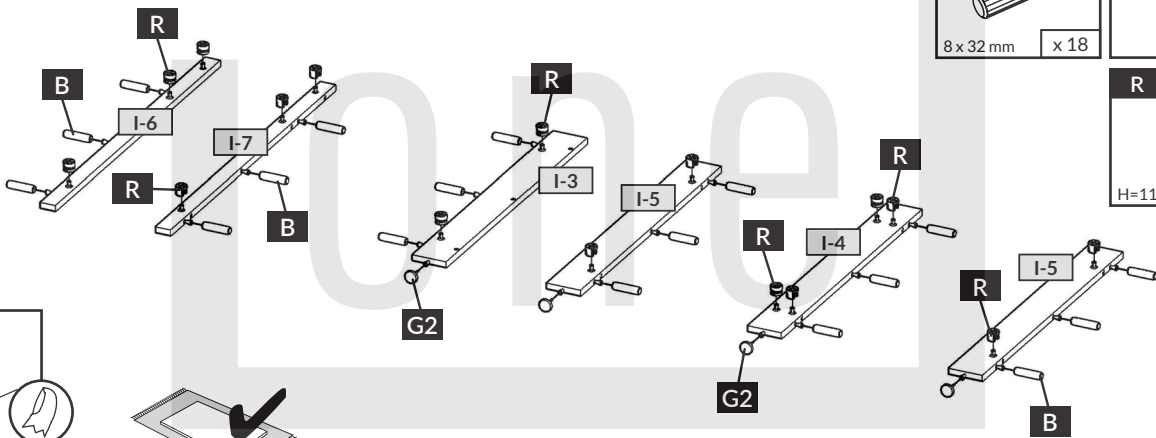
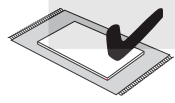
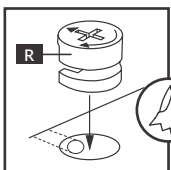

13

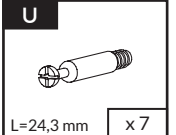
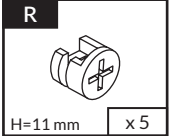
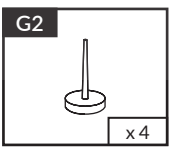
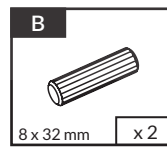
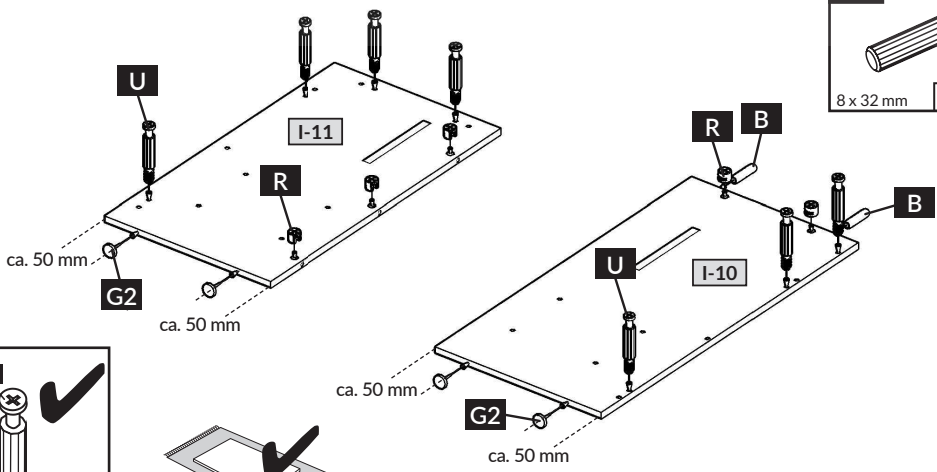
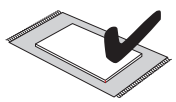
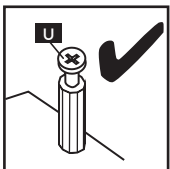
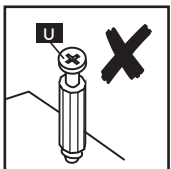
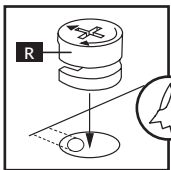

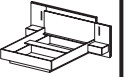

14

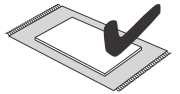
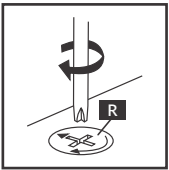
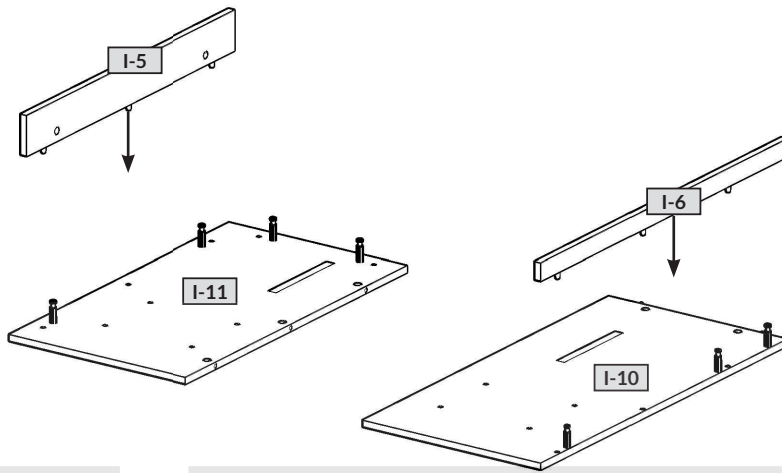

15

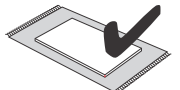
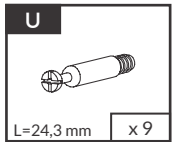
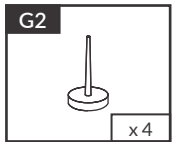
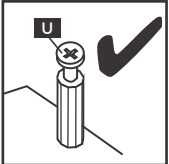
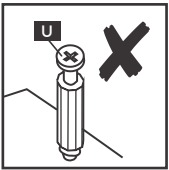
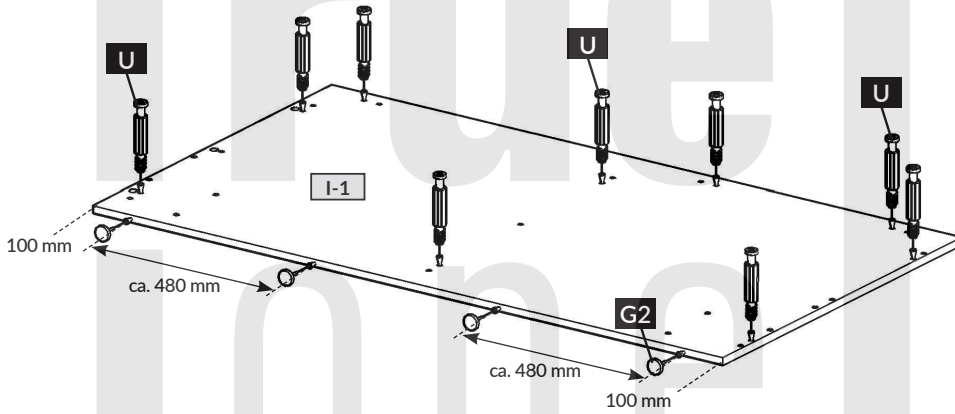

16

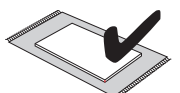
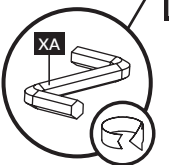
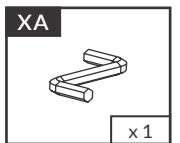
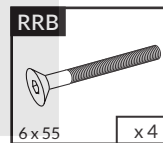
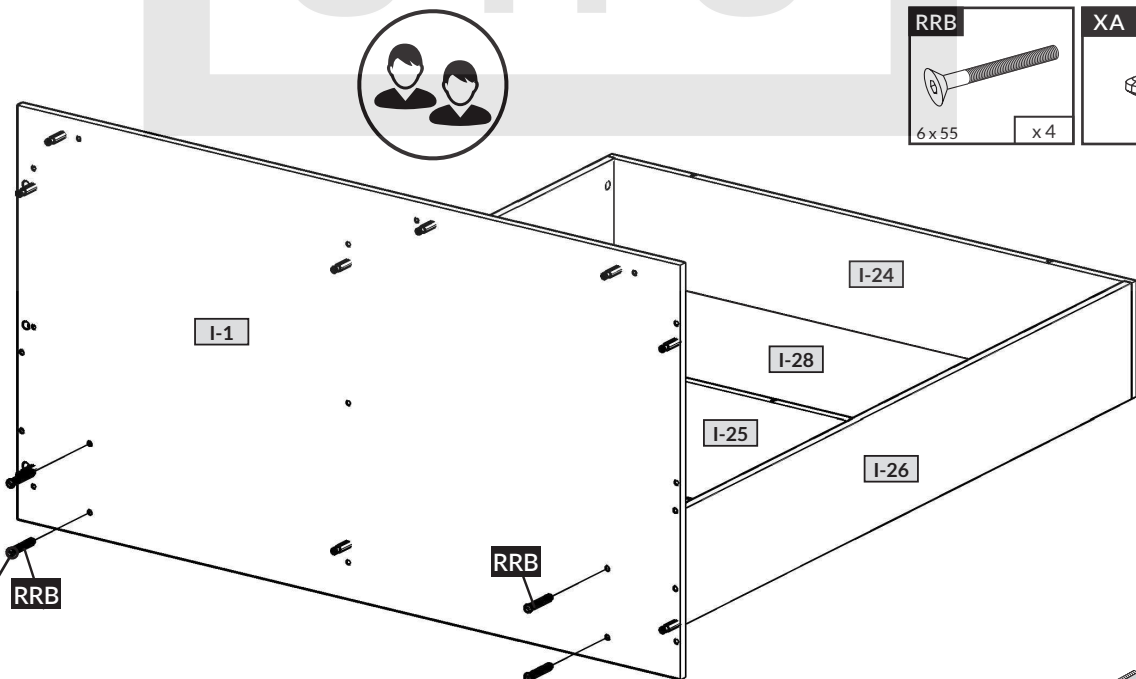



17

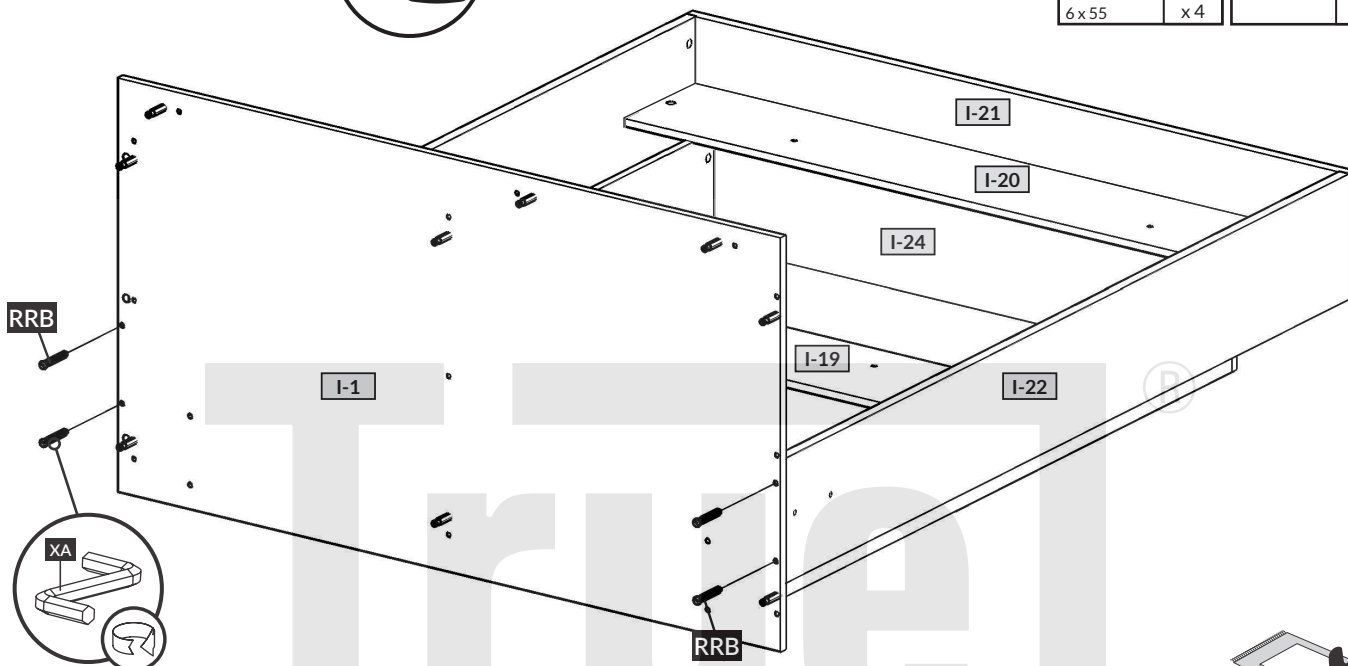
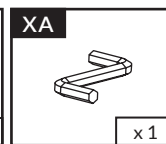
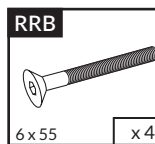

18

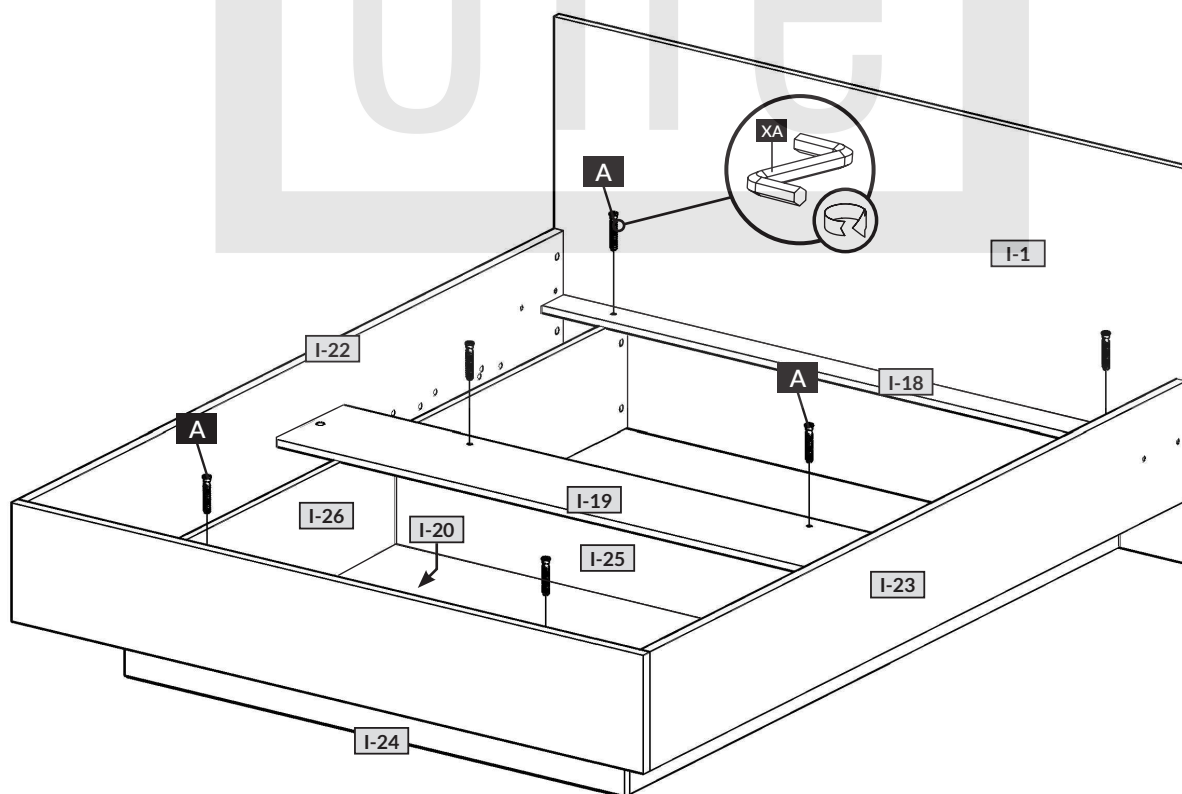
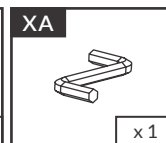
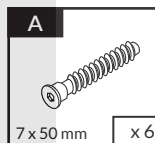



19

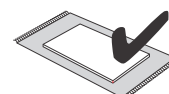
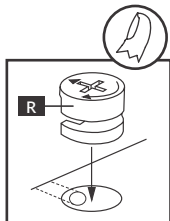
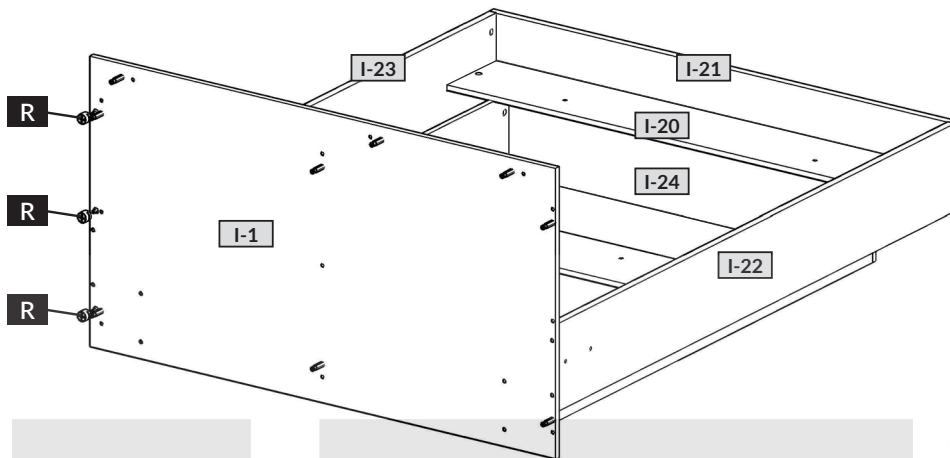
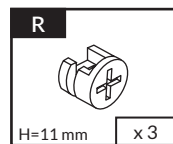

20

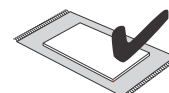
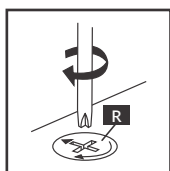
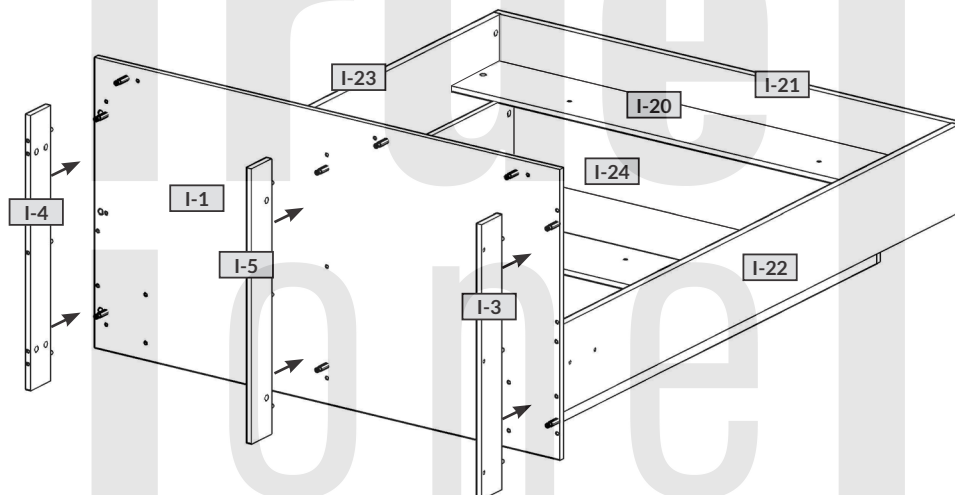

21

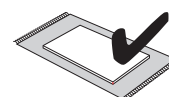
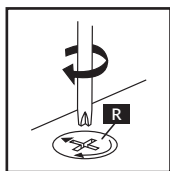
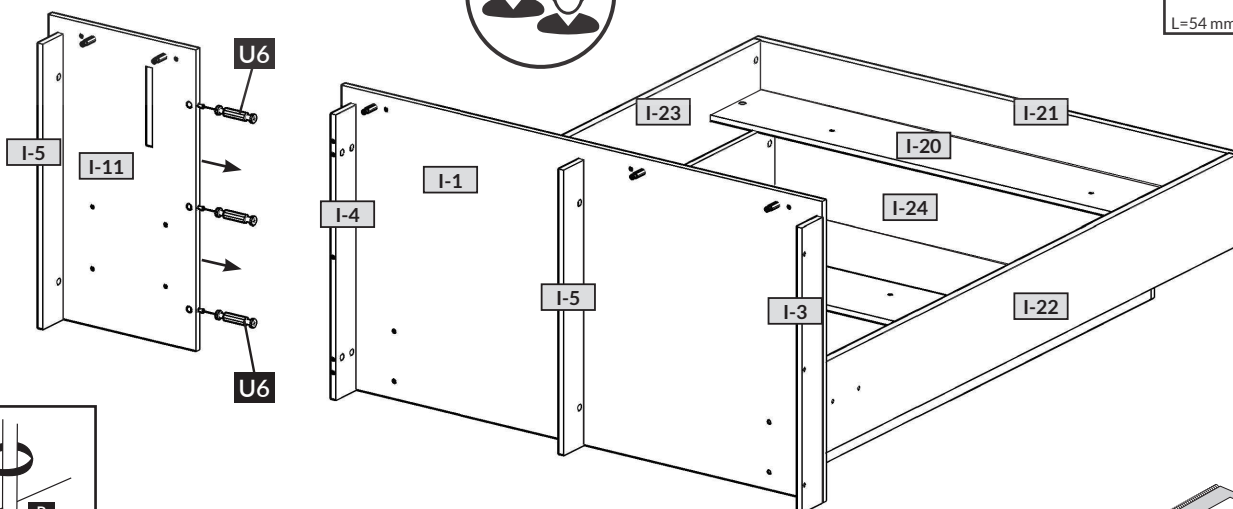
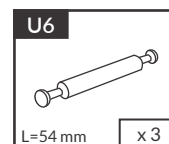

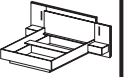

22

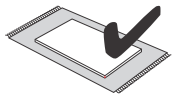
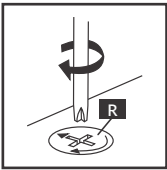
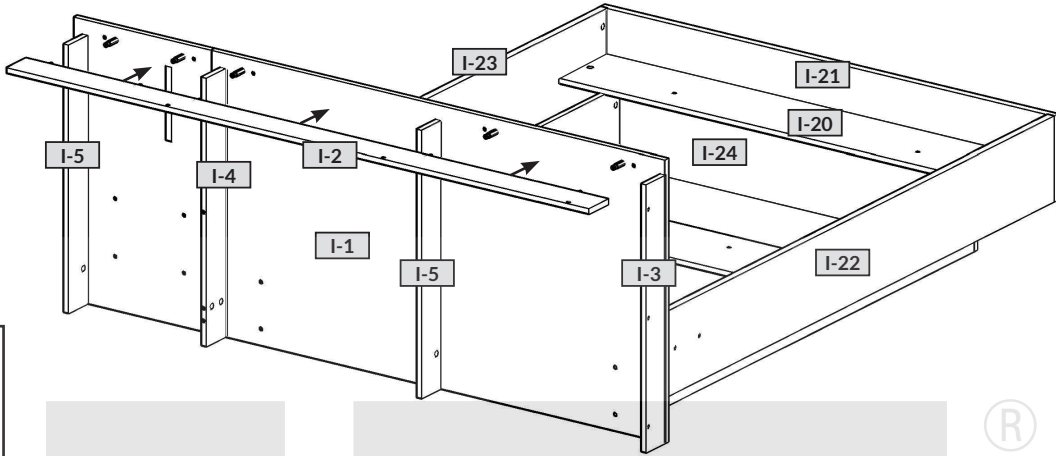

23

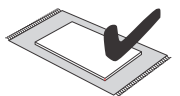
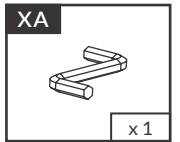
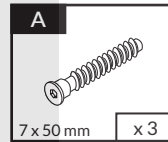
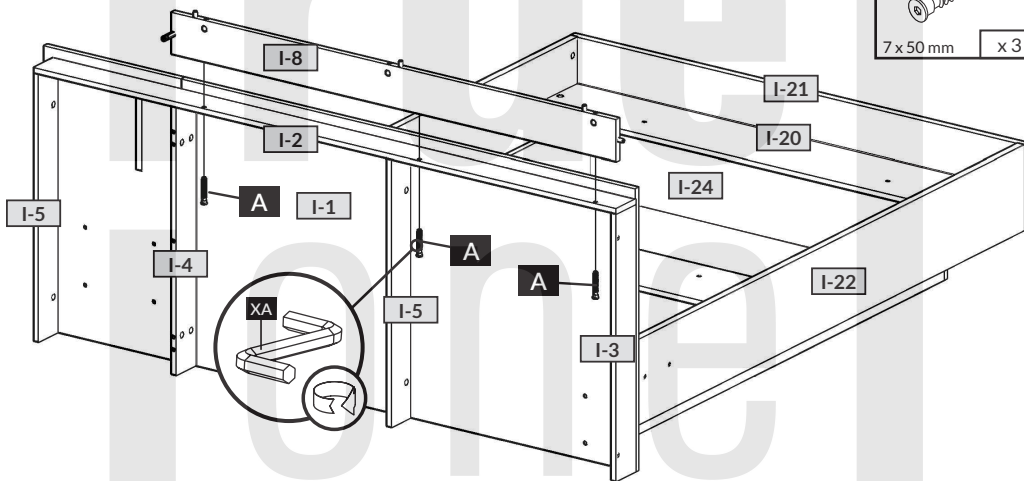

24

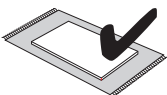
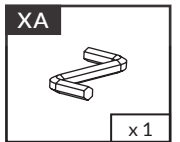
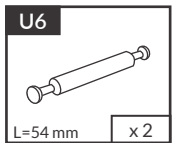
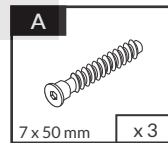
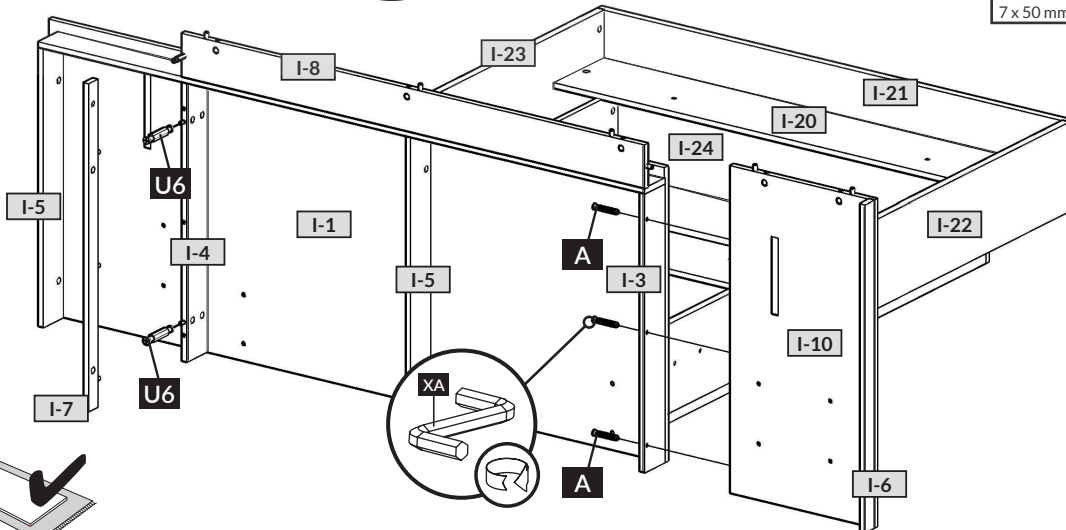

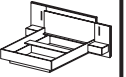

25

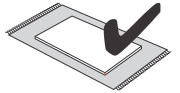
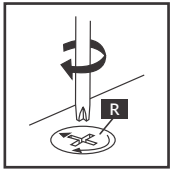
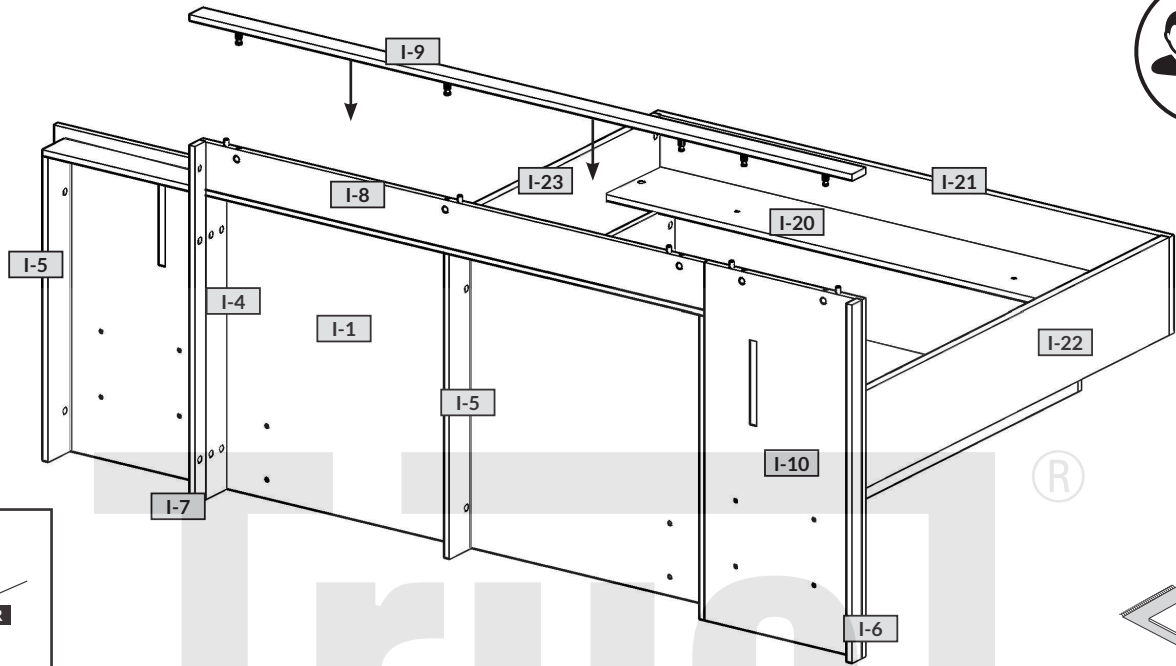

26

B



8 x 32 mm x 16

K



L=250 mm x 2

O2



x 2

R



H=11 mm x 8

T3



5 x 9 mm x 12

U

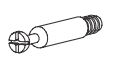

L=24,3 mm x 8

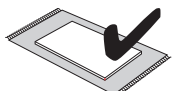
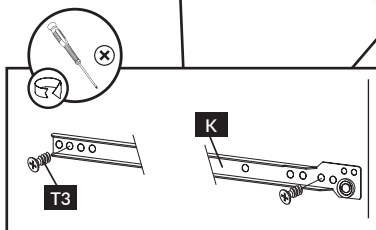
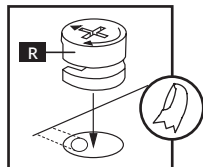
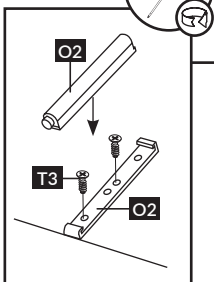
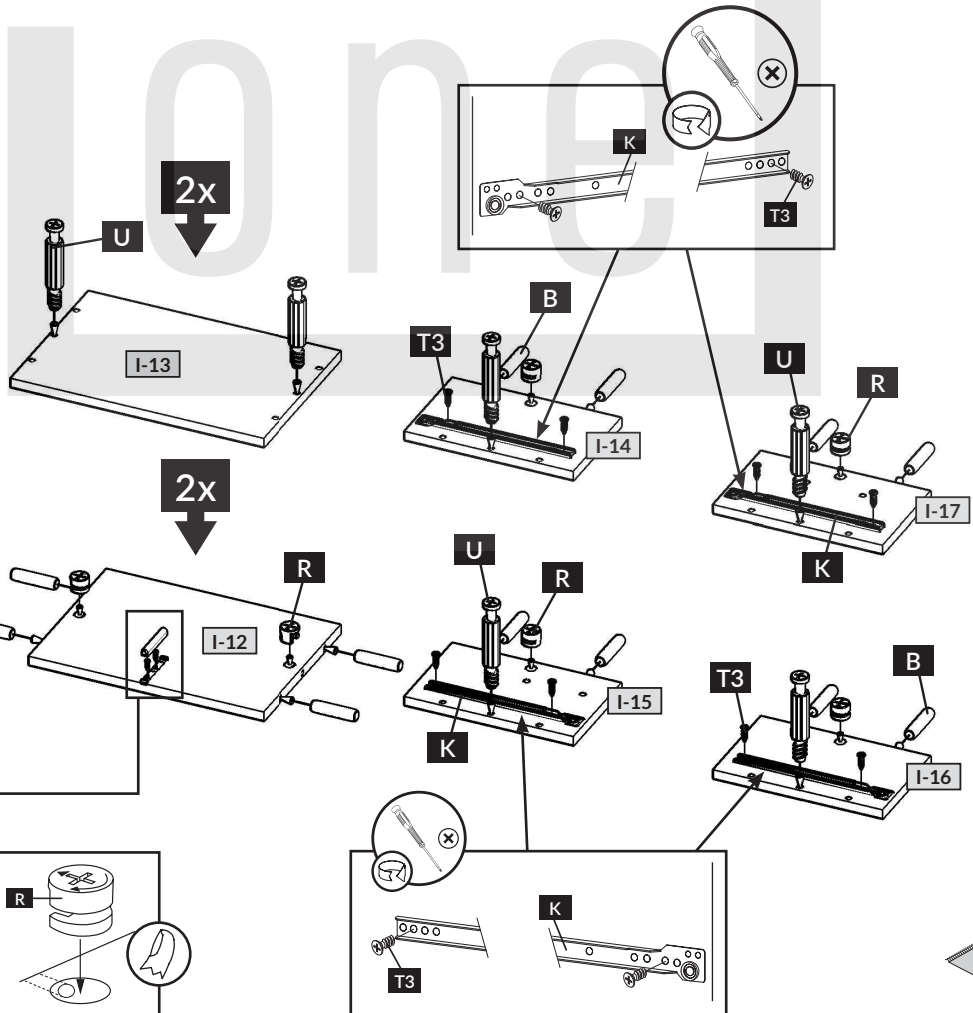
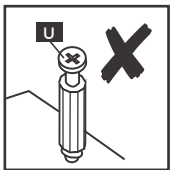

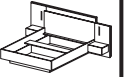

27

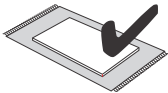
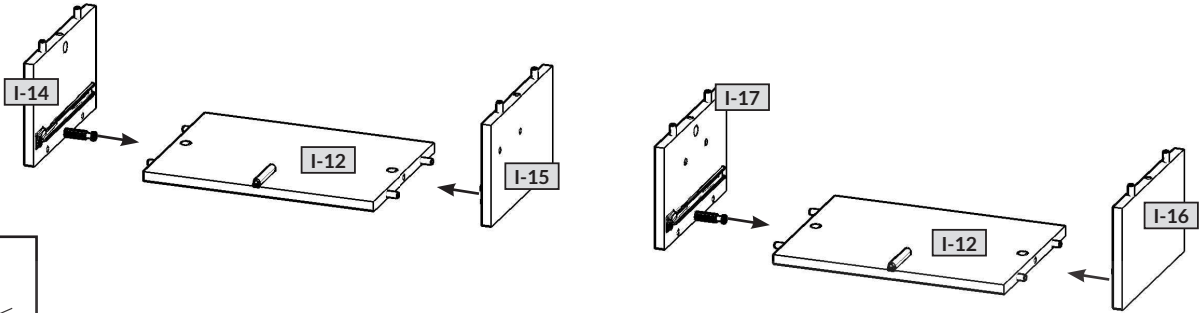

28

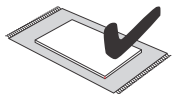
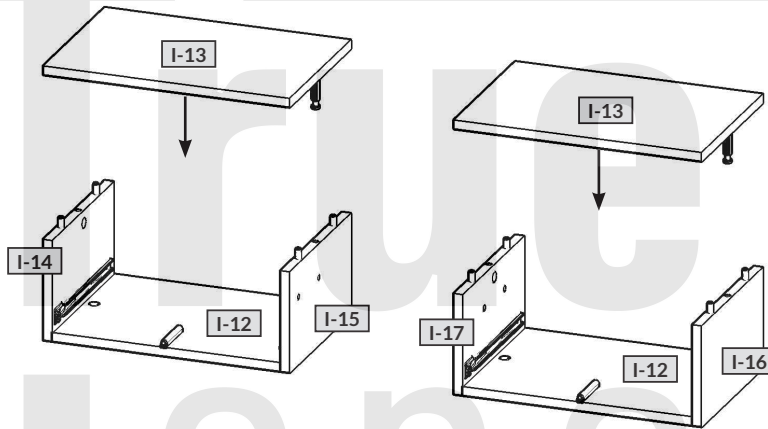

29

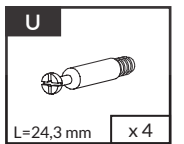
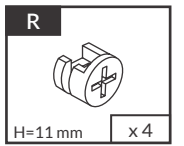
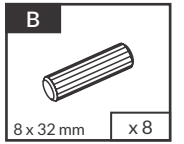
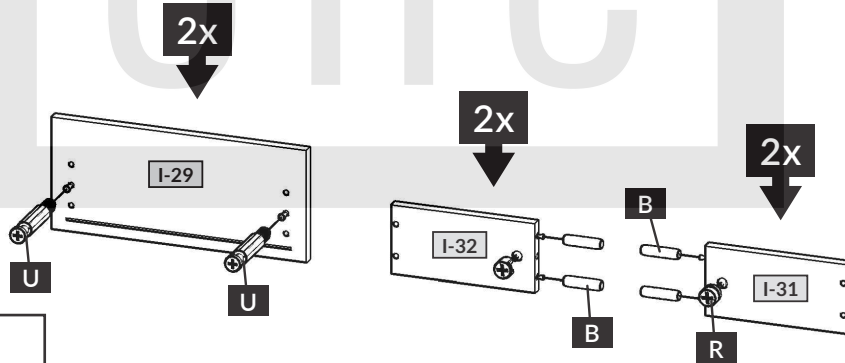
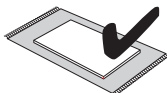
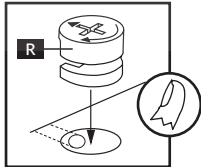
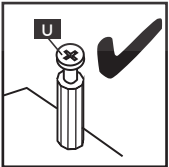
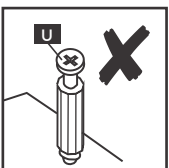

30

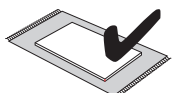
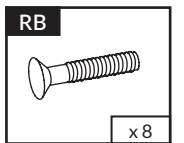
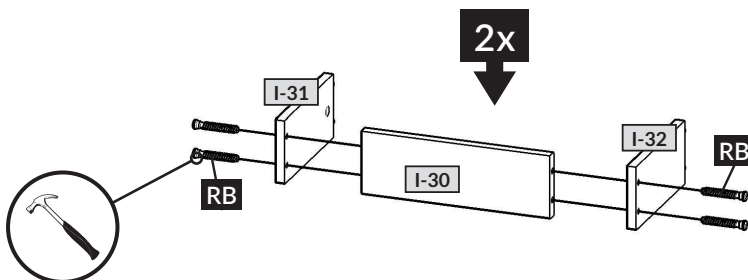

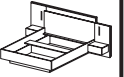

31

2x

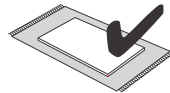
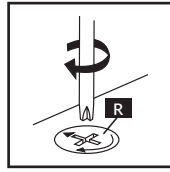
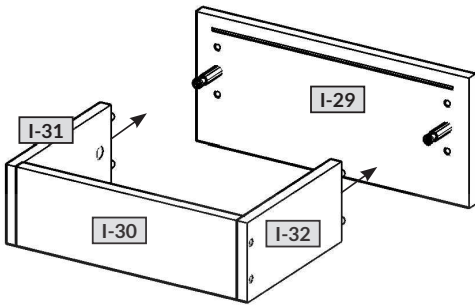

32

2x

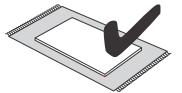
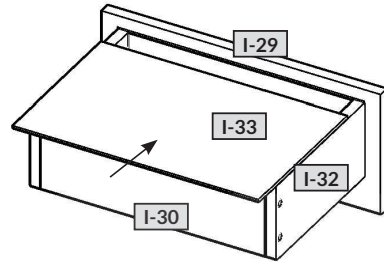

33

2x

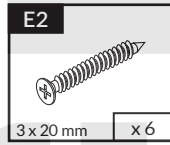
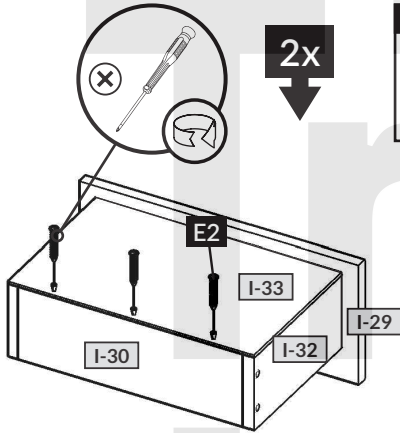

34

2x

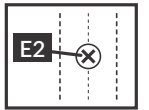
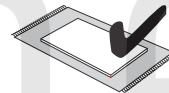
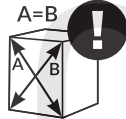
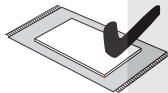
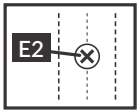
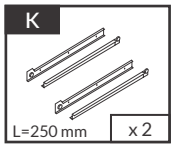
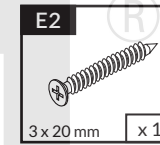
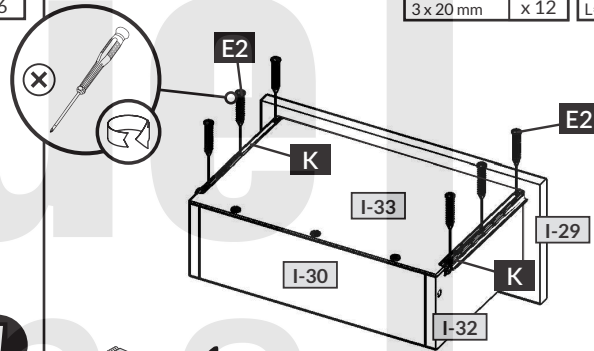

35

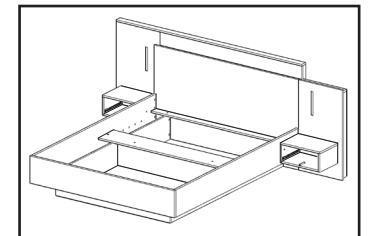
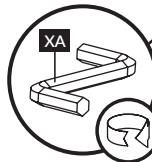
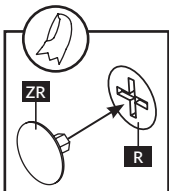
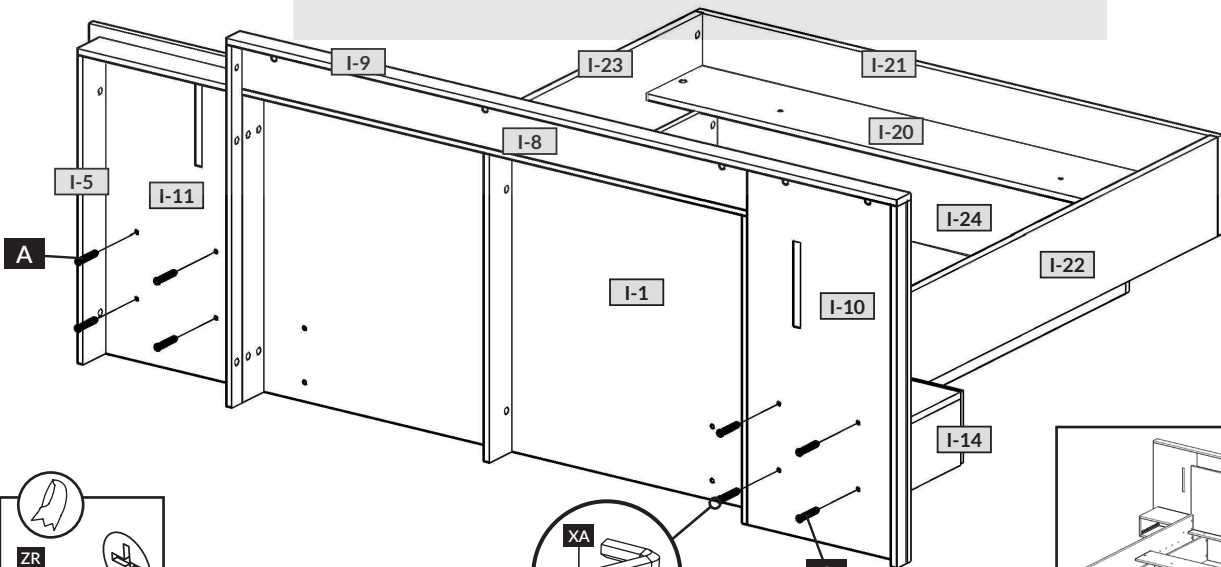
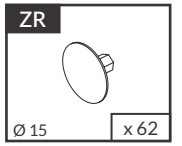
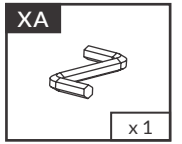
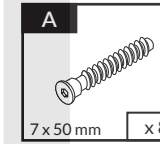

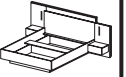

36

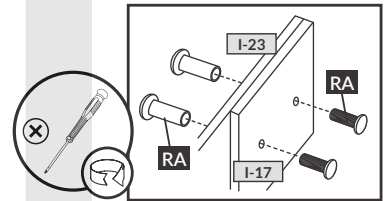
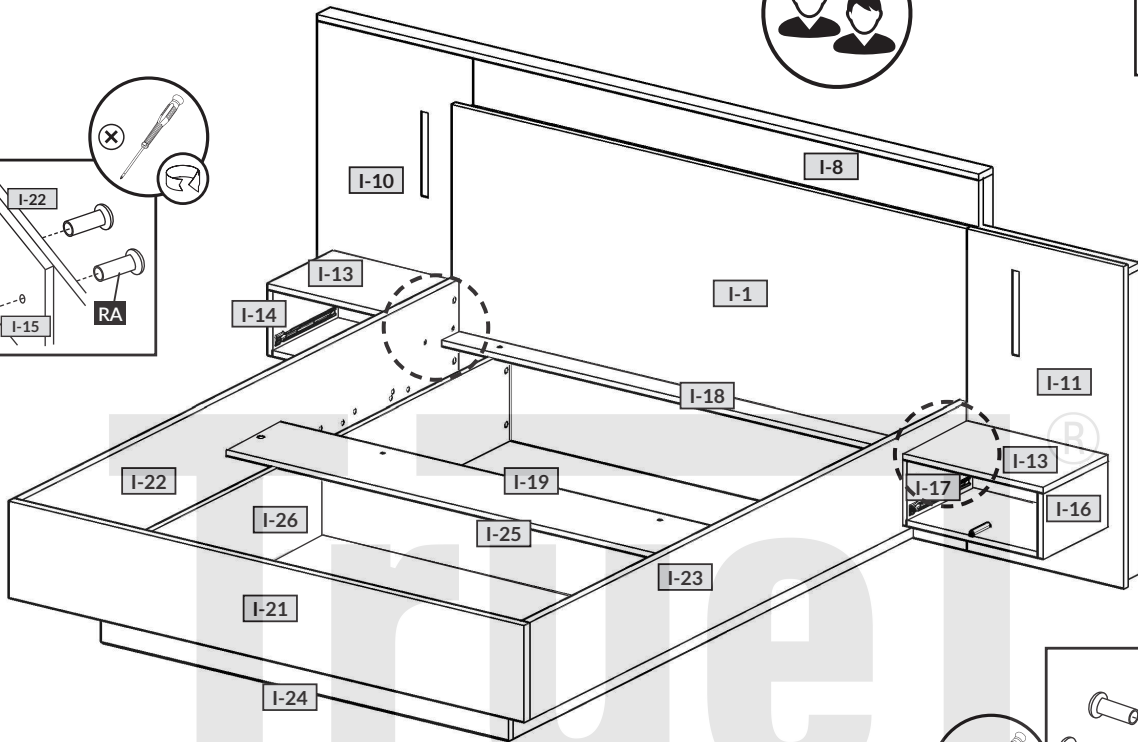
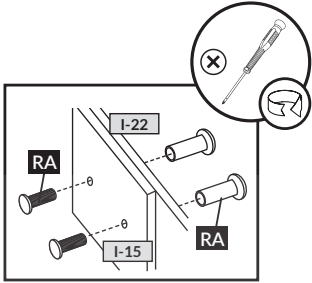
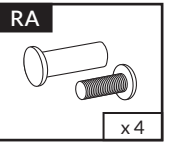

37

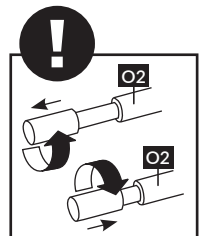
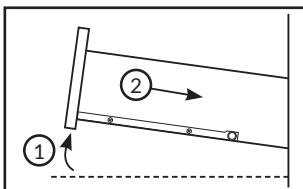
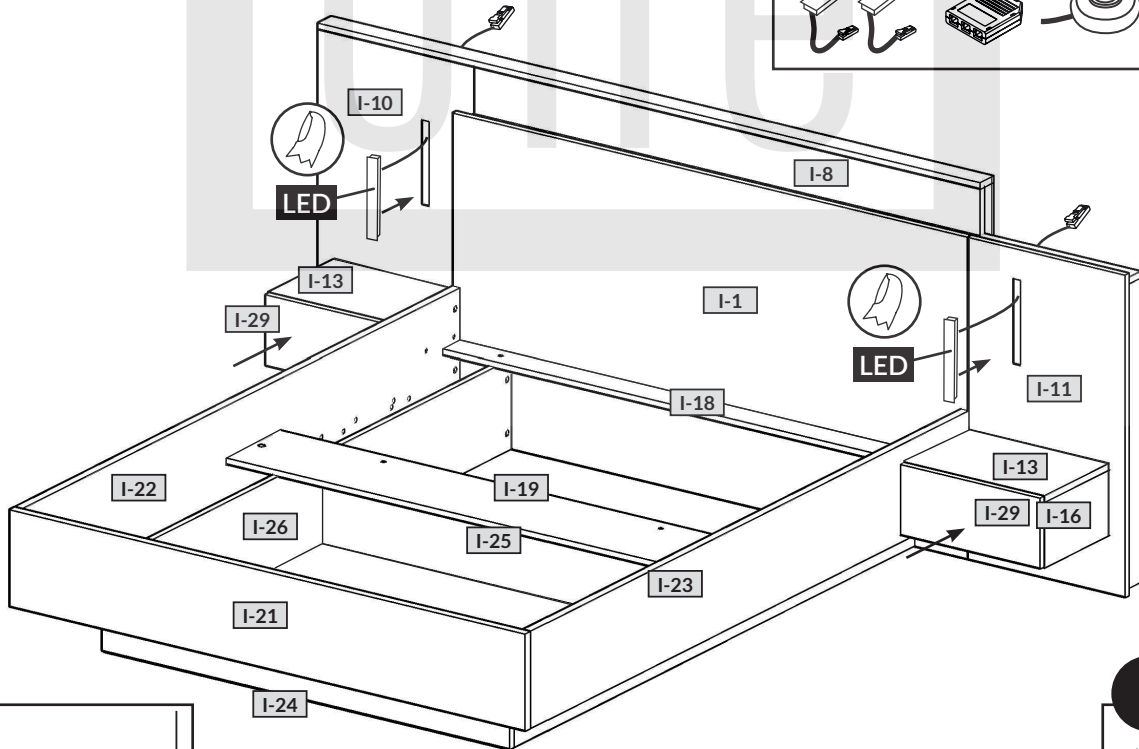
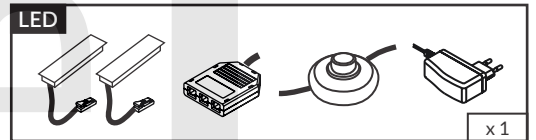

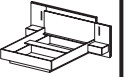

A

B

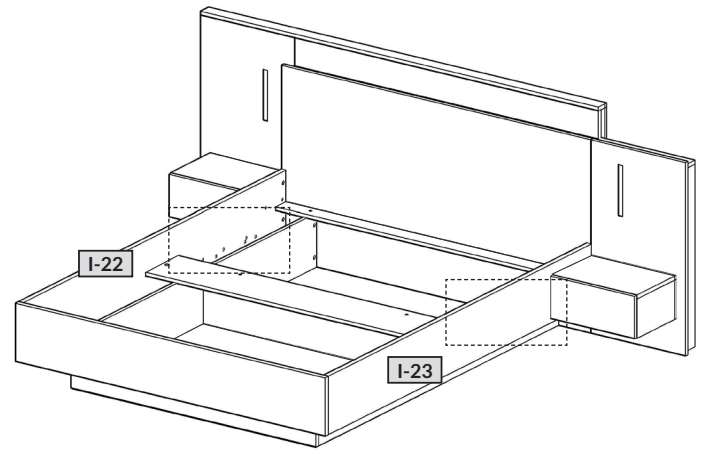
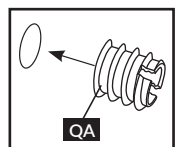
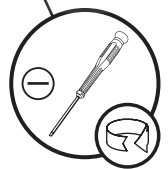
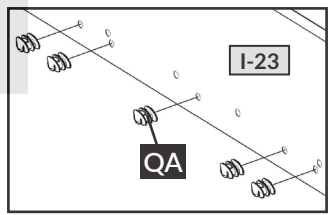
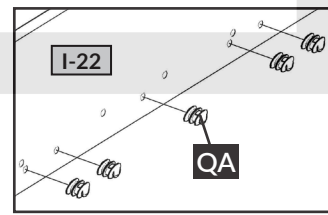
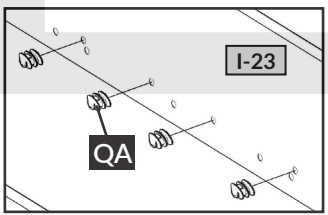
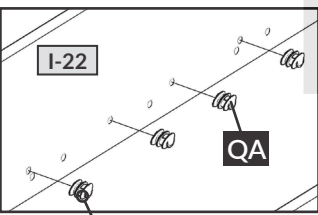
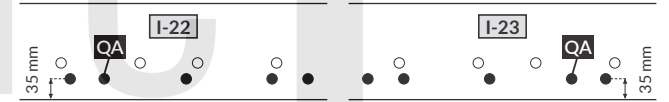
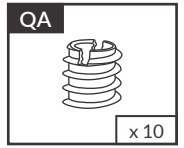
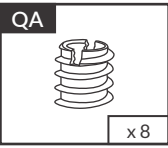
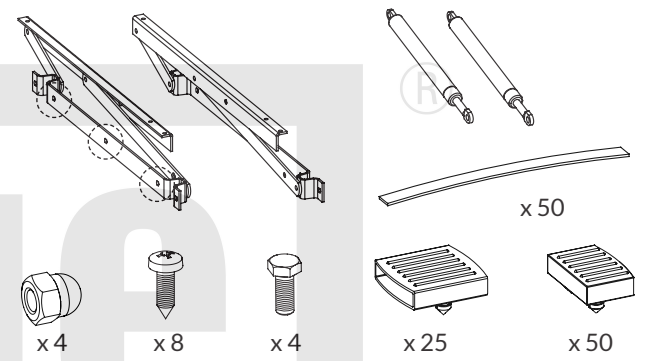
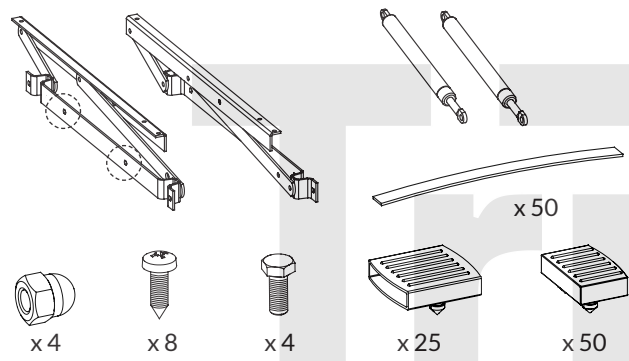
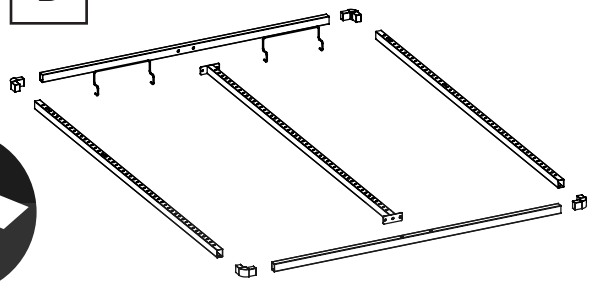
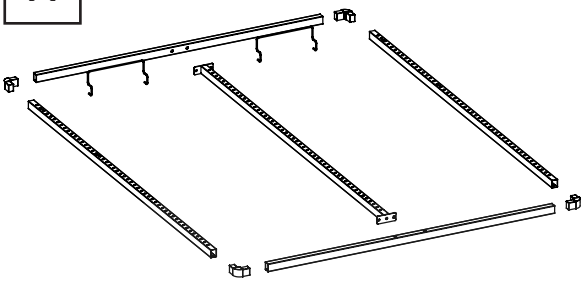

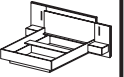

A

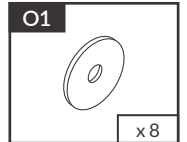
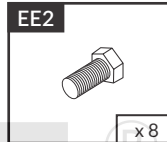
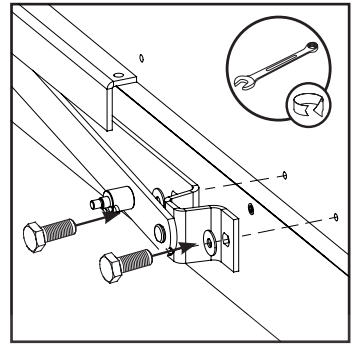
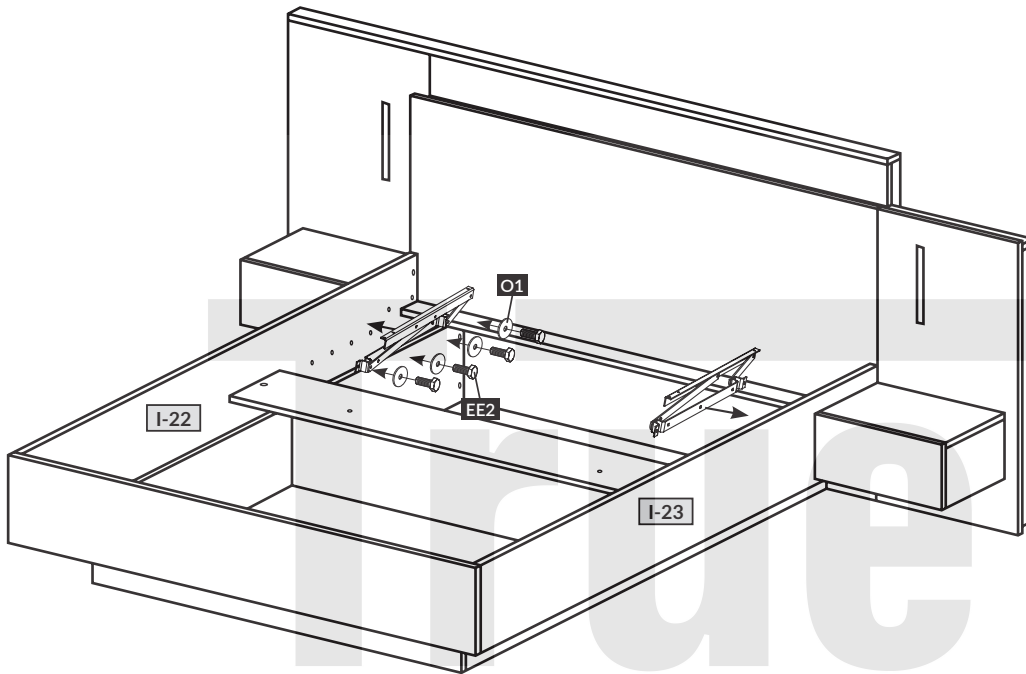

B

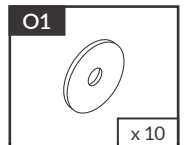
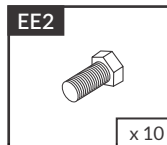
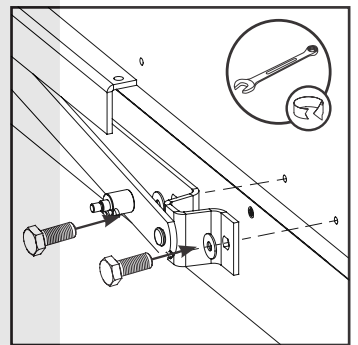
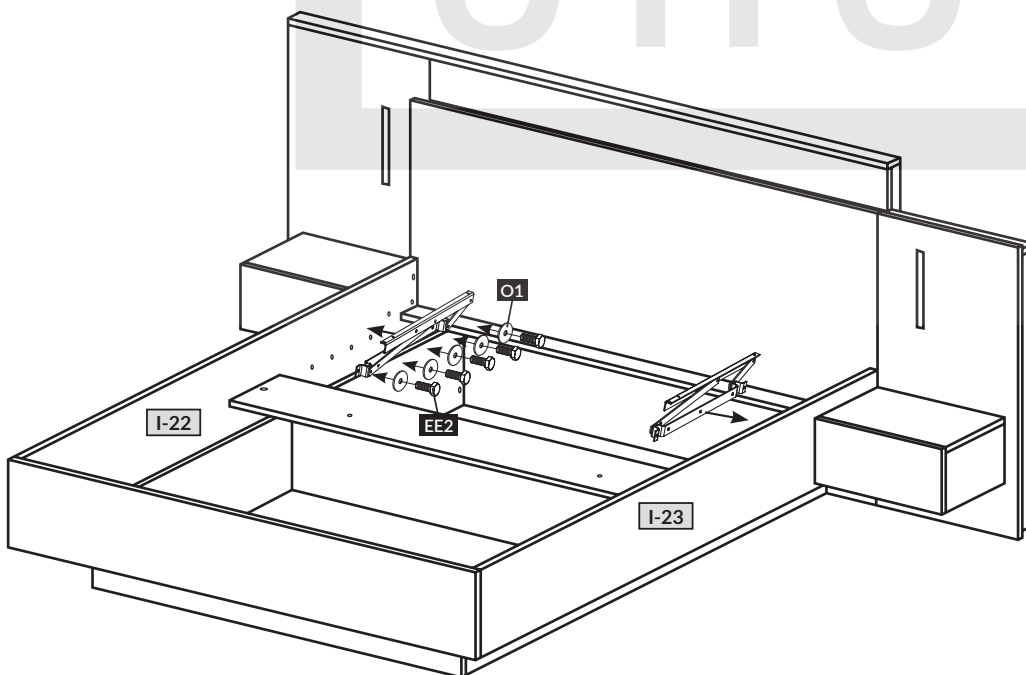

Name • Nom • Nome • Naam • Nazwa • Иméно
• Názov • Név • Denumire • Isim • Извание

Nr • No • N° • Номер • Č • Sz

Typ • Type • Tip • Típus • Tipo • Tun

DANNY

D Unser Direktservice für Beschlagteile
Sollte Ihnen ein Beschlagteil fehlen, können Sie diese Servicekarte
direct an die untenstehende Nummer senden. Wir können allerdings
nur Beschlagteile auf diesem Weg verschicken. Sollen Sie eine andere
Beanstandung an Ihrem Möbelstück haben, so wenden Sie sich bitte
direkt an Ihr Möbelhaus.

GB Our direct order service for fitting
If a fitting should be missing to you, you know this service map
directly following number faxes. We can in this way send away
however only fitting. If you should have another objection to your
piece of furniture, then they turn please to your furniture house.

CZ Naše přímé služby pro kování
Chybí-li vám nějaký díl z kování, můžete tuto servisní kartu odfaxovat
přímo na níže uvedeně číslo. Touto cestou však můžeme zoslat jen
díly kování. Pokud byste reklamovali jiný díl nábytku, obraťte se přímo
na svého prodejce nábytku.

F Bien étudier la notice de montage
Repérez les pièces constituant votre meuble. Regroupez et contrôlez la
quincaillerie. Munissez - vous de l'outillage nécessaire. Aménagez -
vous une zone de montage. Procédez au montage. Ne jamais forcer
les assemblages. Resserrez les vis après quelques temps d'usage.
Gardez votre notice de montage, si une pièce venait à manquer, elle
serait le plus clair moyen de communiquer avec votre magasin.

I Il nostro servizio diretto per l'ordine della ferramenta
Nel caso vi mancassero dei pezzi, potete spedire fax questa carta di
servizi direttamente al seguente numero. Per altri reclami al vostro
mobile, potete rivolgervi al vostro mobilificio.

BG Директно обслужаване на еднотелни делци "Обзор"
Ако ви недостает делци от еднотелното обзраване, можете да
послате директно по факс тази сервисна карта на номера долу.
Можем да ви доставим само делци. Ако имате друга претензия
за мебелта си, моля, обърнете се директно към вашия магазин
за мебели.

NL Onze directservice voor losse onderdelen
Wanneer er een onderdeel mist kunt u deze servicekaart direct aan
onderstaand faxnummer sturen. Wij kunnen alleen langs deze weg
onderdelen versturen. Mocht u een ander probleem aan uw meubel
hebben verzeken wij u contact op te nemen met uw meubeldealer.

PL Nasz bezpośredni serwis części montażowych
Jeżeli brakuje części koniecznych do montażu, prosimy o przesłanie
nam tej karty serwisowej na niżej podany numer faxu. Możemy w ten
sposób przysłać państwu tylko brakujące części. W przypadku innych
objawów dotyczących mebla, prosimy o zgłoszenie ich do salonu
meblowego w którym został dokonany zakup.

HR Servis za okove
U slučaju da nedostaje neki od dijelova molimo vas da na dolje
navedeni Fax broj posaljete ovaj servisni obrazac. Na ovaj način mogu
se dostaviti samo okovi. U slučaju da imate dodatne prigovore vezane
uz komad namještaja molimo vas da se obratite izravno trgovini
namještaja gdje je isti kupljen.

HU Direktszolgáltatunk vasalattal esetén
Ha hiányzik egy vasalat, ezt a kártyát közvetlenül elfaxolhatja az alább
található faxszáma. Azonban csak vasalattal tudunk így küldeni.
Amennyiben másféle reklamációt áll fenn bútorárbaját illetően,
forduljon közvetlenül a bútorházzal.

SK Naše priamy servis pre časťi kovania
Ak by Vám chýbala nejaká časť kovania, môžete poslať túto servisnú
kártyu priamo na nižšie uvedené číslo faxu. Dielty kovania vieme poslať iba
týmto spôsobom. Ak by ste mali inú reklamáciu ohľadom Vašho nábytku,
obráťte sa priamo na Vašu predajnú nábytku.

SLO Naše direktno služne storitve za okovje
Ce vam manjka kakšno okovje, lahko to servisno kartico pošljete po
faksu direktno na spodnjo številko. Po tej poti vam lahko pošljemo
samo okovje. Če želite reklamirati kakšen drug del pohištva, se obrnite
neposredno na vaše trgovino pohištva.

RO Service-ul nostru direct pentru feronerie
In cazul in care va lipsesc o piesa de feronerie puteti sa trimitezi
direct acest card de service pe fax la numarul de mai jos. Noi nu
putem expedia piese de feronerie decat pe acest fel de cale. Decat avezi o
alta reclamatie referitoare la piesa de mobilier, atunci va rugam sa va
adresezi direct la magazinul dvs. de mobilier.

RUS Наш прямой сервис для поставок фурнитуры
Если окажется, что Вам не хватает того или иного элемента
фурнитуры, Вы можете отправить сервисную карту по Факсу
непосредственно на нижеприведенный номер. Однако, таким
образом мы можем пересылать лишь фурнитуру. Если же у Вас
возникнут иные претензии относительно приобретенной мебели,
пожалуйста, обращайтесь непосредственно в организацию,
осуществившую продажу.

S Vår direktservice för beslagdelar
Om du saknar en beslagdel kan du faxa detta servicekort direkt till
numret som anges ned. Tänk på att detta är den enda möjligheten att
skicka beslagdelar till dig. Om du vill reklamera din möbel av en
annan anledning måste du kontakta ditt möbelhus direkt.

ES Nuestro servicio directo para accesorios
Si le falta algún accesorio, puede enviar esta tarjeta de servicio
directamente a la siguiente dirección. No obstante, por este método
solo podemos enviar accesorios. Si tiene alguna otra objeción sobre su
mueble, consulte directamente con su mueblería.

TR Donatilar için doğrudan servisi
Bir donatınız eksikse bu servis kartını doğrudan aşağıda bulunan
adrese doğrudan mail yazabilirsiniz. Sadece bu yolla donatıları
gönderebiliriz. Mobilyanızda başka şikayetleriniz varsa lütfen doğrudan
mobilya satıcınıza danışın.

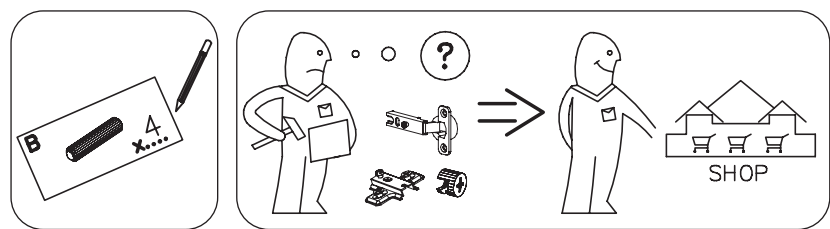
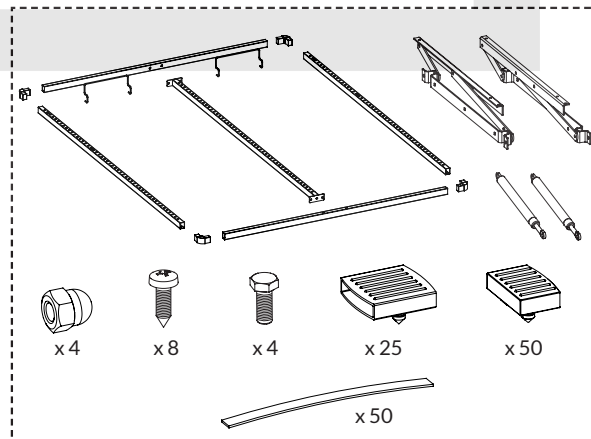
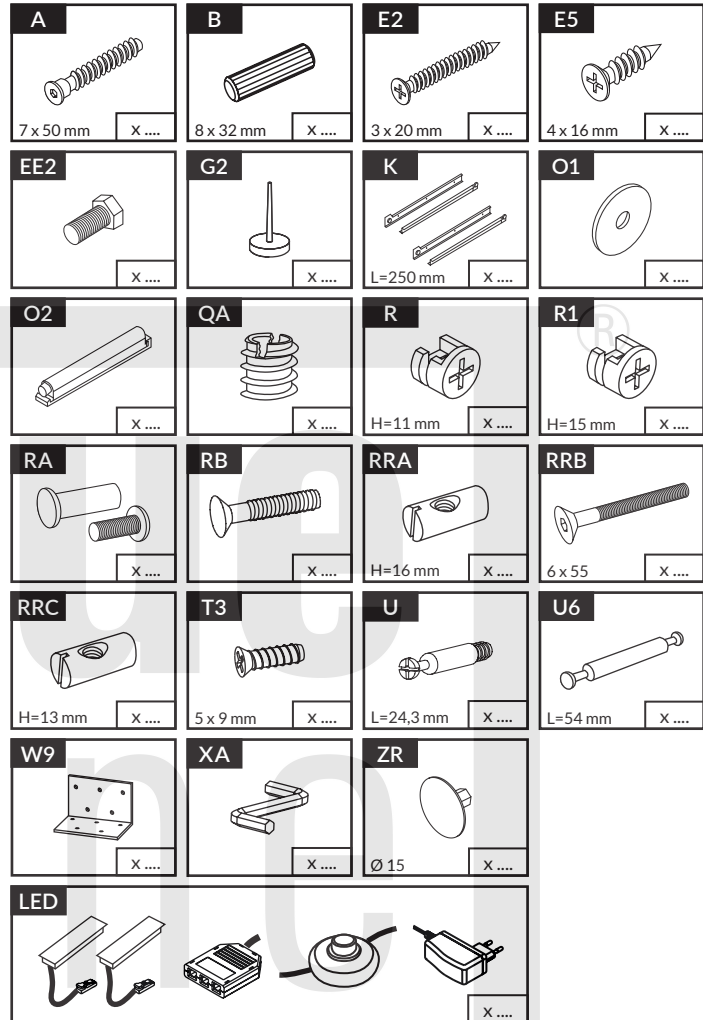

Name • Nom • Nome • Naam • Nazwa • Иméно • Názov • Név • Denumire • Isim • Извание	Nr • No • N° • Номер • Č • Sz	Typ • Type • Tip • Típus • Tipo • Tun
DANNY	— —	I

D Unser Direktservice für Beschlagteile
 Sollte Ihnen ein Beschlagteil fehlen, können Sie diese Servicekarte direkt an die untenstehende Nummer senden. Wir können allerdings nur Beschlagteile auf diesem Weg verschicken. Sollen Sie eine andere Beanstandung an Ihrem Möbelstück haben, so wenden Sie sich bitte direkt an Ihr Möbelhaus.

GB Our direct order service for fitting
 If a fitting should be missing to you, you know this service map directly following number faxes. We can in this way send away however only fitting. If you should have another objection to your piece of furniture, then they turn please to your furniture house.

CZ Naše přímé služby pro kování
 Chybí-li vám nějaký díl z kování, můžete tuto servisní kartu odfaxovat přímo na níže uvedeně číslo. Touto cestou však můžeme zoslat jen díly kování. Pokud byste reklamovali jiný díl nábytku, obraťte se přímo na svého prodejce nábytku.

F Bien étudier la notice de montage
 Regroupez les pièces constituant votre meuble. Regroupez et contrôlez la quincaillerie. Munissez - vous de l'outillage nécessaire. Aménagez - vous une zone de montage. Procédez au montage. Ne jamais forcer les assemblages. Resserrez les vis après quelques temps d'usage. Gardez votre notice de montage, si une pièce venait à manquer, elle serait le plus clair moyen de communiquer avec votre magasin.

I Il nostro servizio diretto per l'ordine della ferramenta
 Nel caso vi mancassero dei pezzi, potete spedire fax questa carta di servizi direttamente al seguente numero. Per altri reclami al vostro mobile, potete rivolgervi al vostro mobilificio.

BG Директно обслужаване на еднотелни делци "Обзор"
 Ако ви недостига някое от еднотелните делци, можете директно да изпратите тази картичка за директно обслужаване на еднотелните делци по факс на следния номер. Ако имате друга претензия относно мебелта си, моля да се свържете директно с вашия магазин.

NL Onze directservice voor losse onderdelen
 Wanneer er een onderdeel mist kunt u deze servicekaart direct aan onderstaand faxnummer sturen. Wij kunnen alleen langs deze weg onderdelen versturen. Mocht u een ander probleem aan uw meubel hebben verzoeken wij u contact op te nemen met uw meubeldealer.

PL Nasz bezpośredni serwis części montażowych
 Jeżeli brakuje części koniecznych do montażu, prosimy o przesłanie nam tej karty serwisowej na niżej podany numer faxu. Możemy w ten sposób przysłać państwu tylko brakujące części. W przypadku innych obiekacji dotyczących mebla, prosimy o zgłoszenie ich do salonu meblowego w którym został dokonany zakup.

HR Servis za okove
 U slučaju da nedostaje neki od dijelova molimo vas da na dolje navedeni Fax broj posaljete ovaj servisni obrazac. Na ovaj način mogu se dostaviti samo okovi. U slučaju da imate dodatne prigovore vezane uz komad namještaja molimo vas da se obratite izravno trgovini namještaja gdje je isti kupljen.

HU Direktszolgáltatunk vasalattal eseten
 Ha hiányzik egy vasalat, ezt a kártyát közvetlenül elfaxolhatja az alább található faxszáma. Azonban csakis vasalattal tudunk így küldeni. Amennyiben másféle reklamációt áll fenn bútorárbájáért illetlen, forduljon közvetlenül a bútorházzhoz.

SK Naše priamy servis pre časti kovaní
 Ak by Vám chýbala nejaká časť kovaní, môžete poslať túto servisnú kartu poslať faxom priamo na nižšie uvedené faxové čílo. Diely kovaní vieme poslať iba týmto spôsobom. Ak by ste mali inú reklamáciu ohľadom Vášho nábytku, obráťte sa priamo na Vašu predajnú nábytku.

SLO Naše direktno služne storitve za okovje
 Če vam manjka kakšno okovje, lahko to servisno kartico pošljete po faxu direktno na spodnjo številko. Po tej poti vam lahko pošljemo samo okovje. Če želite reklamirati kakšen drug del pohištva, se obrnite neposredno na vaše trgovino pohitva.

RO Service-ul nostru direct pentru feronerie
 În cazul în care vă lipseşte o piesă de feronerie puteţi să trimiteţi direct acest card de service pe fax la numărul de mai jos. Noi nu putem expedia piese de feronerie decât pe această cale. Dacă aveţi o altă reclamaţie referitoare la piese de mobilier, atunci vă rugăm să vă adresaţi direct la magazinul dvs. de mobilă.

RUS Наш прямой сервис для поставок фурнитуры
 Если окажется, что Вам не хватает того или иного элемента фурнитуры, Вы можете отправить сервисную карту по Факсу непосредственно на нижеприведенный номер. Однако, таким образом мы можем пересылать лишь фурнитуру. Если же у Вас возникнут иные претензии относительно приобретенной мебели, пожалуйста, обращайтесь непосредственно в организацию, осуществляющую продажу.

S Vår direktservice för beslagdelar
 Om du saknar en beslagdel kan du faxa detta servicekort direkt till numret som anges ned. Tänk på att detta är den enda möjliga vägen att skicka beslagdelar till dig. Om du vill reklamera din möbel av en annan anledning måste du kontakta ditt möbelhus direkt.

ES Nuestro servicio directo para accesorios
 Si le falta algún accesorio, puede enviar esta tarjeta de servicio directamente a la siguiente dirección. No obstante, por este método solo podemos enviar accesorios. Si tiene alguna otra objeción sobre su mueble, consulte directamente con su mueblería.

TR Donatilar için doğrudan servisimiz
 Bir donatınız eksikse bu servis kartını doğrudan aşağıda bulunan adrese doğrudan mail yazabilirsiniz. Sadece bu yönde donatılar gönderilebilir. Mobilyanızda başka şikayetleriniz varsa lütfen doğrudan mobilya satıcınıza danışın.

nr	↔ [mm]	↓ [mm]	↗ [mm]	Menge	Colli
I-1	900	1644	16	x1	1/2
I-2	2112	100	16	x1	2/2
I-3	852	100	16	x1	1/2
I-4	852	100	16	x1	2/2
I-5	852	100	16	x2	1/2
I-6	1000	44	16	x1	2/2
I-7	1000	44	16	x1	2/2
I-8	132	1612	16	x1	2/2
I-9	2112	60	16	x1	2/2
I-10	1000	500	16	x1	1/2
I-11	900	500	16	x1	1/2
I-12	418	300	16	x1	1/2
I-13	450	300	16	x2	2/2
I-14	184	300	16	x1	2/2
I-15	184	300	16	x1	2/2
I-16	184	300	16	x1	2/2
I-17	184	300	16	x1	2/2

nr	↔ [mm]	↓ [mm]	↗ [mm]	Menge	Colli
I-18	1600	80	16	x1	1/2
I-19	1600	250	16	x1	1/2
I-20	1600	250	16	x1	1/2
I-21	1645	272	22	x1	2/2
I-22	2022	270	22	x1	2/2
I-23	2022	270	22	x1	2/2
I-24	1301	250	16	x1	1/2
I-25	1268	250	16	x1	1/2
I-26	1850	250	16	x1	2/2
I-27	1850	250	16	x1	2/2
I-28	1296	1002	3	x1	1/2
I-29	446	196	16	x2	1/2
I-30	361	120	16	x2	2/2
I-31	250	120	16	x2	2/2
I-32	250	120	16	x2	2/2
I-33	392	256	3	x2	1/2

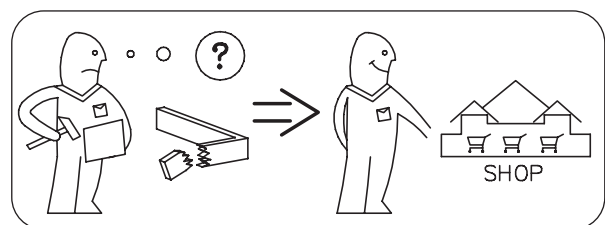
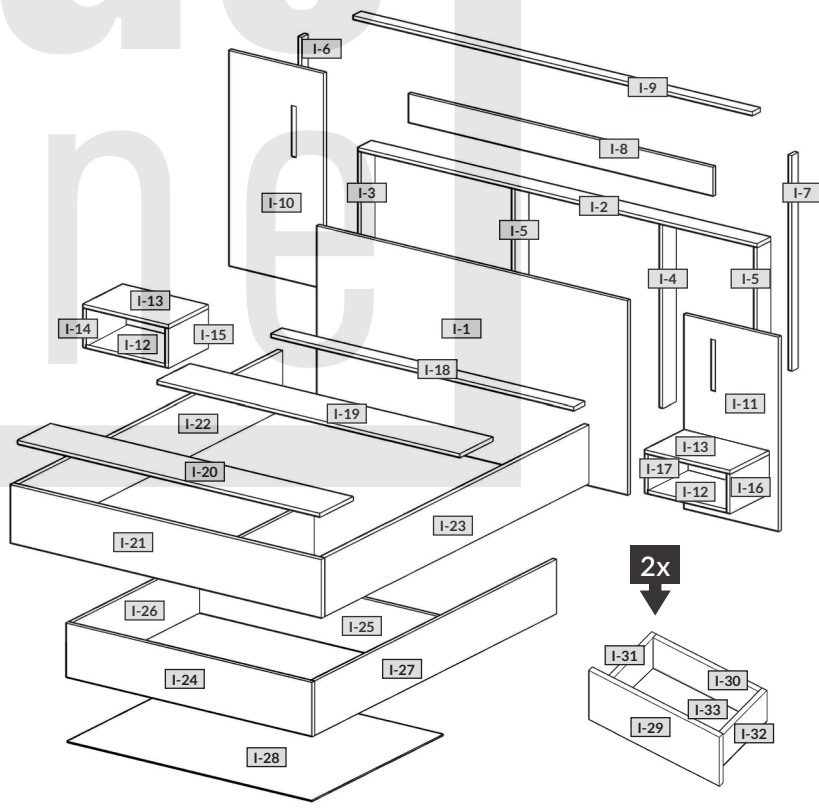

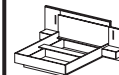

Achtung • Opgelet • Uwaga • Dikkat • Вниманіе •
Attention • Upozorneni • Figyelem • Allenzione • Atentie



D	Überschreiten Sie die angegebenen Maximalbelastungen nicht. Andernfalls kann das Möbelstück beschädigt oder zerstört werden.
GB	Do not exceed the maximum loads specified. Otherwise, the furniture may sustain damage or be irreparably damaged.
NL	Overschrijd de aangegeven maximale belastingen niet. Anders kan het meubelstuk worden beschadigd of vernield.
PL	Nie wolno przekraczać podanych maksymalnych wartości obciążenia. W innym przypadku można mebel uszkodzić lub zniszczyć.
TR	Belirtilen azami yuk degerini asmayiniz, aksi taktirde mobilya parçasi zarar gorebilir veya kullanilamaz hale gelebilir.
RU	Не допускается превышение указанных максимальных нагрузок. В противном случае возможно повреждение или разрушение мебели.
FR	Ne dépassez pas les charges maximum indiquées. Sinon, le meuble peut être endommagé ou détruit.
CZ	Nepřekračujte uvedená maximální zatížení. V opačném případě může dojít k poškození nebo zničení nábytku.
HU	Tartsa be az engedélyezett maximális terhelhetőséget/teljesítményt. Különbön a bútor és annak alkatrészei megsérülhetnek, tönkre mehetnek.
IT	Non superare il carico massimo indicato. Altrimenti il mobile rischia di rovinarsi o frantumarsi.
RO	Nu depasiti solictarile maxime specificate. Altfel puteti sa deteriorati sau sa distrugeti piesa de mobilier.
SK	Neprekročte uvedené maximálne zaťaženia. V opačnom prípade sa môže nábytok poškodiť alebo zničiť.
D	Die Befestigung des Möbelstückes an der Wand muss von einer fachkundigen Person vorgenommen werden, da für die Montage an die Wand angepasste Dübel erforderlich sind.
GB	A qualified professional is required when mounting furniture to the wall since dowels corresponding to the wall are required for this.
NL	Een vakkundige persoon dient het meubelstuk aan de muur te bevestigen; voor de montage aan de muur zijn immers aangepaste pluggen vereist.
PL	Mocowanie mebla do ściany mogą przeprowadzić wyłącznie wykwalifikowane osoby, z uwagi na zastosowanie odpowiednio dopasowanych kołków do rodzaju ściany.
TR	Mobilya parçasının duvara sabitlenmesi, duvar montajı için özel uyarlanmış dübeller gerektirdiğinden bu iş sadece bu konuda uzman bir kişi tarafından gerçekleştirilmelidir.
RU	Поскольку для монтажа на стене необходимо использовать специальные дюбели, мебель должна быть закреплена на стене квалифицированным персоналом.
FR	La fixation du meuble contre le mur doit être effectuée par une personne compétente car, pour le montage mural, il faut utiliser des chevilles adaptées.
CZ	Montáž nábytku na stěnu musí provést odborník, protože k montáži na stěnu jsou zapotřebí upravené hmoždinky.
HU	A bútorelemek falra rögzítését szakembernek kell végeznie, mert a rögzítéshez megfelelő tiplit kell használni.
IT	Il fissaggio del mobile alla parete deve essere eseguito esperte, dato che occorrono tasselli adeguati.
RO	Fixarea la perete a piesei de mobilier se realizeaza numai de catre personal competent, deoarece montajul de perete necesita dibluri adecvate.
SK	Upevnenie nábytku na stenu musí vykonať odborník, nakoľko sú pre montáž na stenu potrebné vhodné hmoždinky.

