

EN

Bellamy  
27 Kościuszki Street  
38-500 Sanok  
www.bellamy.pl

The bed complies with safety standards for children's beds in EN 716-1: 2008

PL

Bellamy  
Ul. Kościuszki 27  
38-500 Sanok  
www.bellamy.pl

Produkt odpowiada normom bezpieczeństwa dla łóżeczek dziecięcych wg EN 716-1: 2008

**Lewostronne**  
Left side version

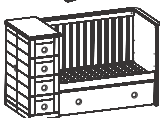
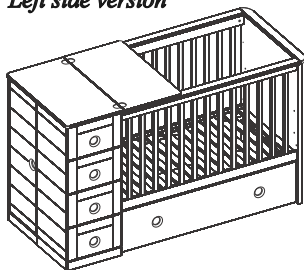

**Prawostronne**  
Right side version

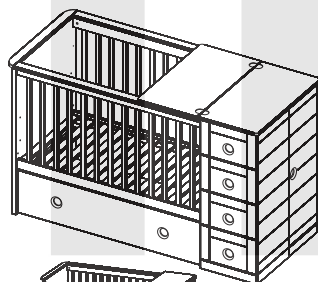

The PASO DOBLE bed allows you to attach the drawer unit on either the left or right side.

The holes marked **P** should be aimed for right side version  
The holes marked **L** should be aimed for the left side version  
The holes marked **P+L** are universal to both ways

### UWAGA:

Drogi Kliencie mamy dla Ciebie łóżeczko, które możesz zmontować jako PRAWOSTRONNE lub LEWOSTRONNE według Twojego upodobania. Otwory podpisane na instrukcji literą **P** należy uzbroić dla uzyskania łóżeczka PRAWOSTRONNEGO, a gdy chcemy mieć łóżeczko LEWOSTRONNE to należy uzbroić otwory podpisane literą **L**. Otwory podpisane **P+L** są uniwersalne.

EN







Returns of the assembled furniture will not be accepted

Before attempting to assemble this product please check the contents of the package. If any components are missing or damaged, please contact the retailer from whom you bought this product.

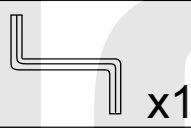
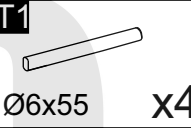
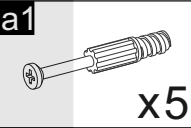
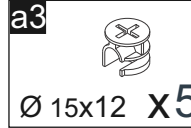
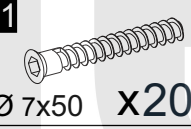
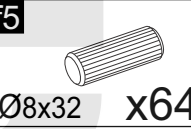
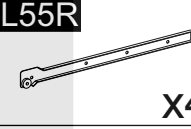
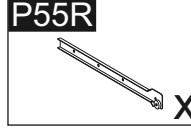
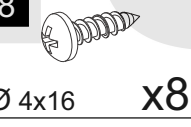
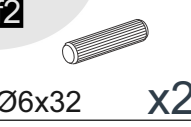
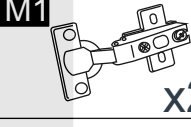
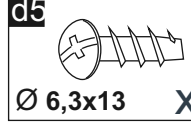
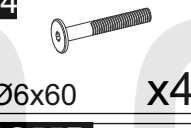
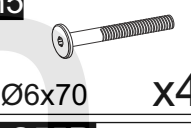
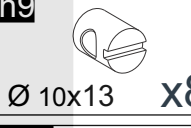
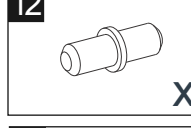
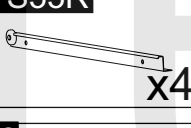
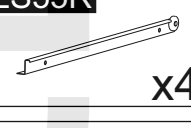
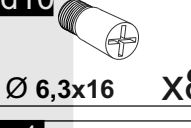
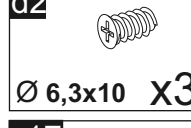
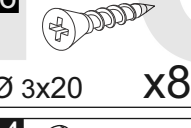
PL

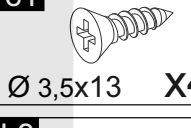
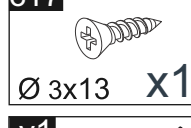
Zwroty skreconych mebli nie sa przyjmowane

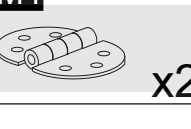
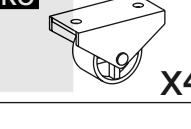
Przed przystapieniem do montazu nalezy sprawdziczy nie brakuje zadnych czesci oraz czy nie sa uszkodzone. Jezeli brakuje czesci lub uszkodzona, prosze kontaktowac siez lokalnym dostawca.

 x1	<b>T1</b>  x4 Ø6x55	<b>a1</b>  x53	<b>a3</b>  x53 Ø 15x12
<b>b1</b>  x20 Ø 7x50	<b>f5</b>  x64 Ø8x32	<b>L55R</b>  x4	<b>P55R</b>  x4
<b>c8</b>  x8 Ø 4x16	<b>f2</b>  x2 Ø6x32	<b>M1</b>  x2	<b>d5</b>  x4 Ø 6,3x13
<b>h4</b>  x4 Ø6x60	<b>h5</b>  x4 Ø6x70	<b>h9</b>  x8 Ø 10x13	<b>i2</b>  x4
<b>PS55R</b>  x4	<b>LS55R</b>  x4	<b>d10</b>  x8 Ø 6,3x16	<b>d2</b>  x32 Ø 6,3x10
<b>c6</b>  x8 Ø 3x20	<b>KLEJ</b>  x1	<b>c1</b>  x4 Ø 3,5x13	<b>c17</b>  x12 Ø 3x13
<b>n4</b>  x3 Amortyzator hałasu/ Bumper	<b>M4</b>  x2	<b>k8</b>  x4	<b>y1</b>  x1 Ø16x346
<b>k18</b>  x4 Rzep/ Hook Loop			

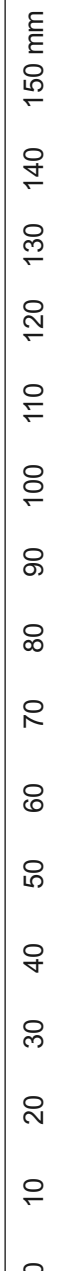

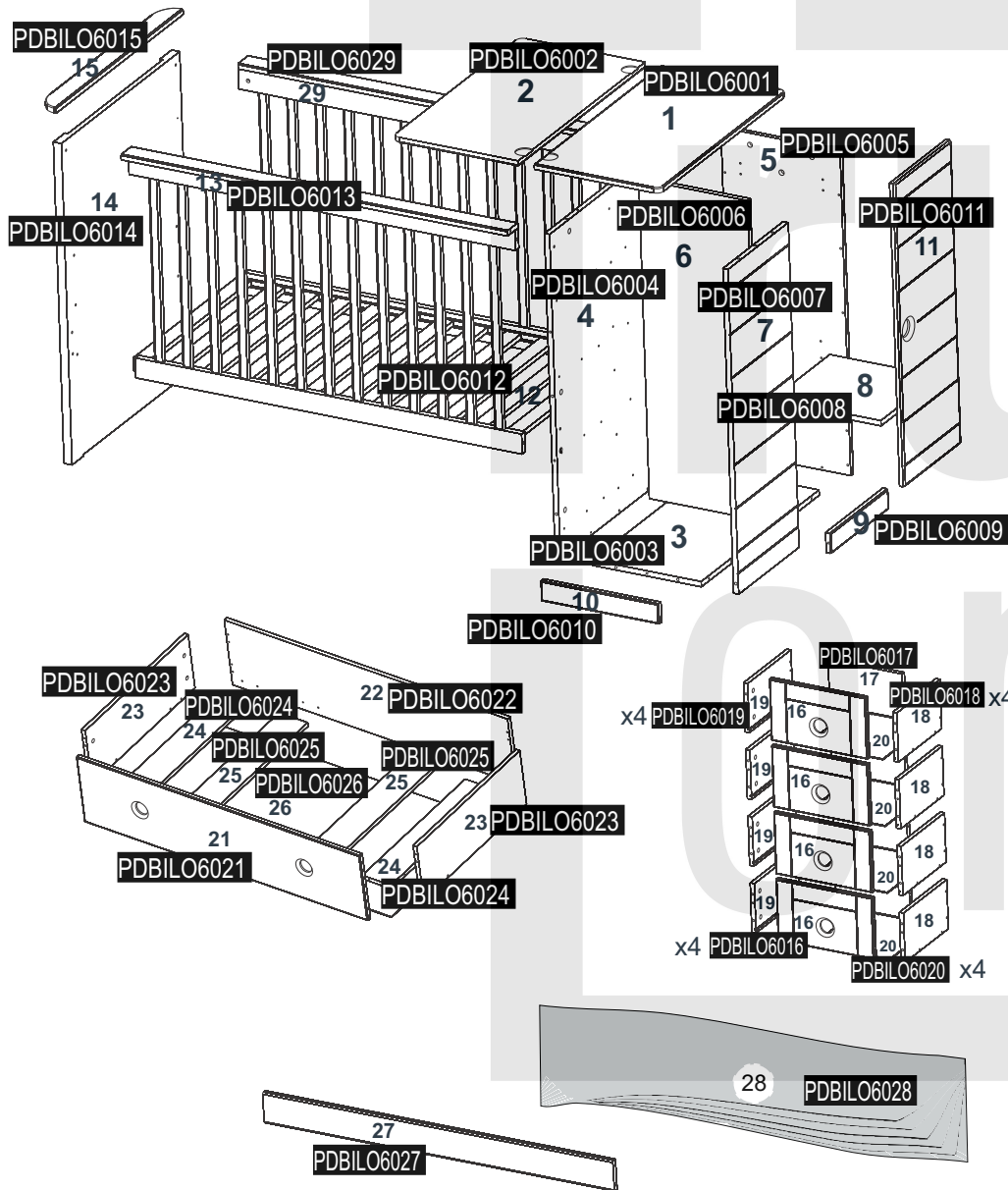
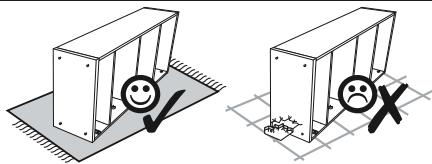

1

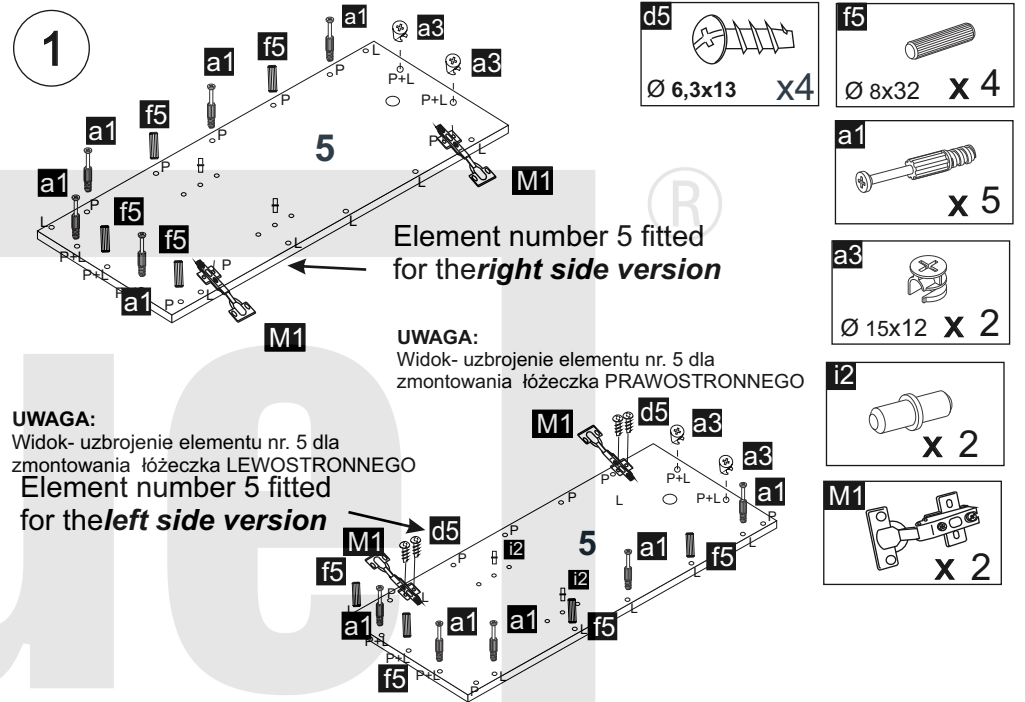

2

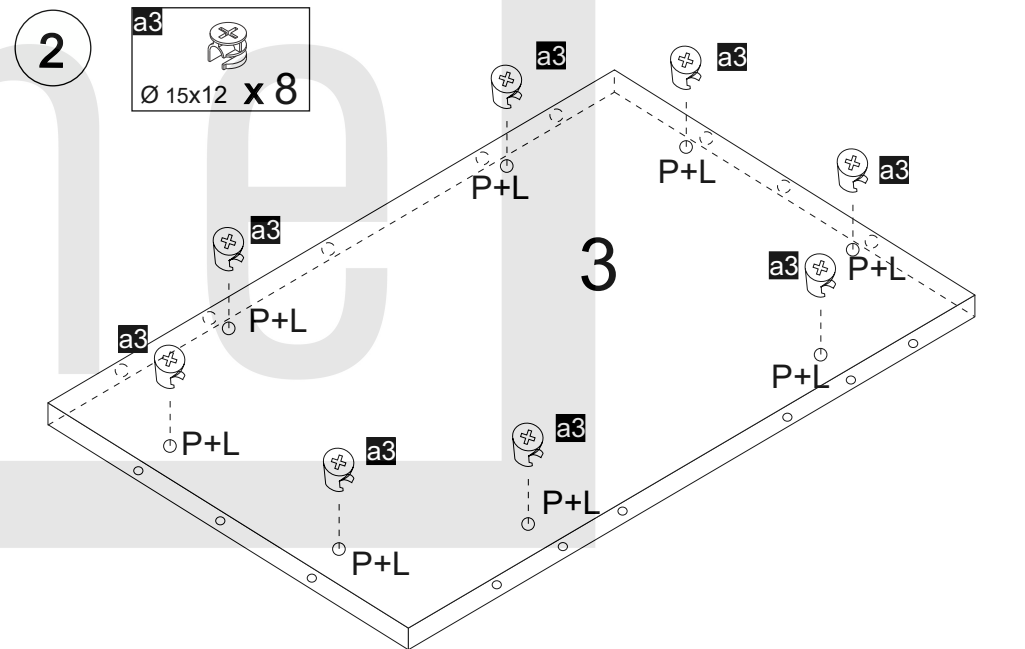

3

Fitting of the element number 4 for the *right side version*

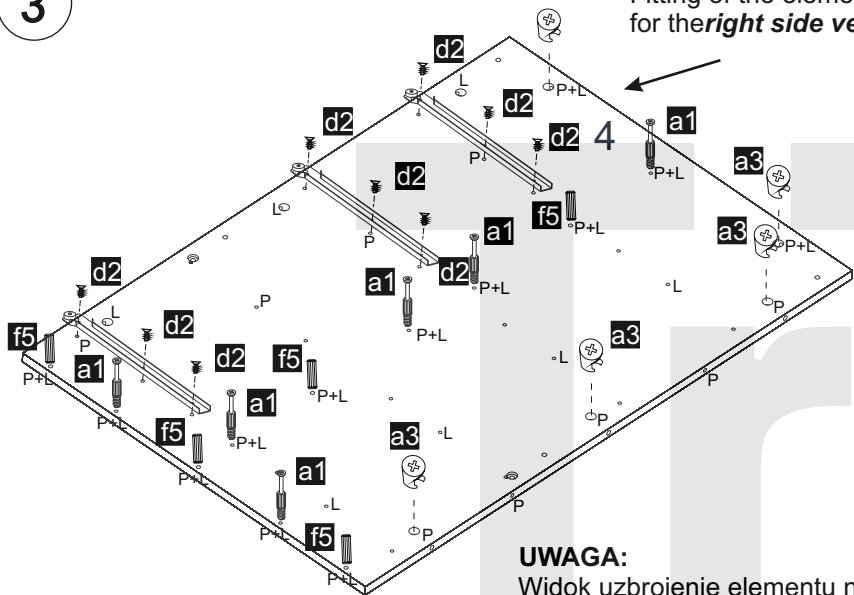

**UWAGA:**  
Widok uzbrojenie elementu nr. 4 dla  
złożenia łożeczka PRAWOSTRONNEGO

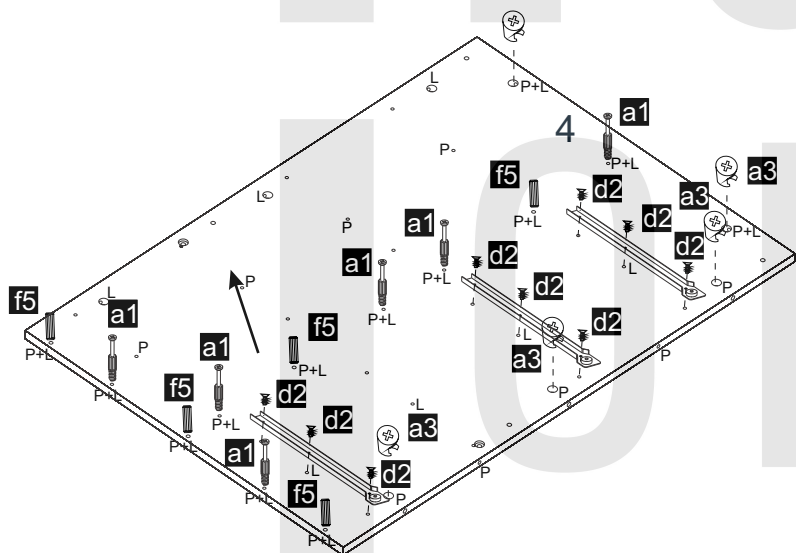

Fitting of the element number 4  
for the *left side version*

**UWAGA:**  
Widok uzbrojenie elementu nr. 4 dla  
złożenia łożeczka LEWOSTRONNEGO

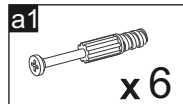
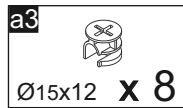
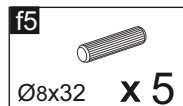
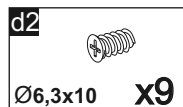

4

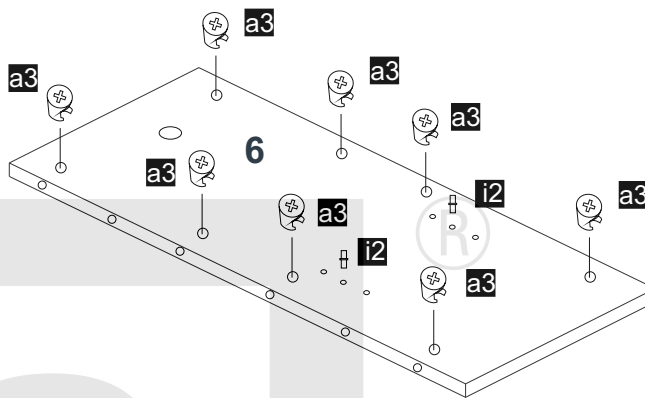
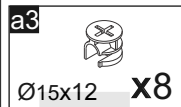
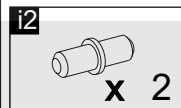

5

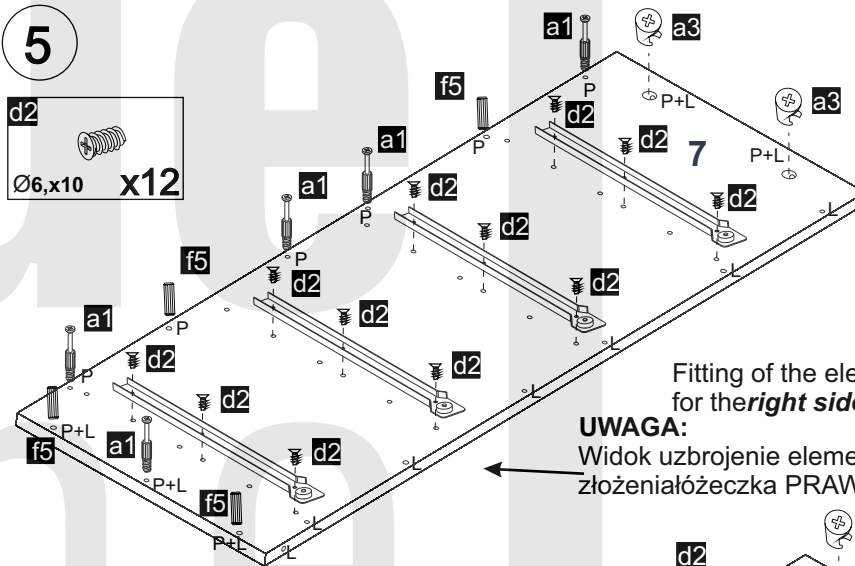
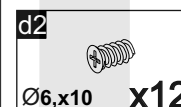

Fitting of the element number 7  
for the *right side version*  
**UWAGA:**  
Widok uzbrojenie elementu nr. 7 dla  
złożenia łożeczka PRAWOSTRONNEGO

Fitting of the element number 7  
for the *left side version*

**UWAGA:**  
Widok uzbrojenie elementu nr. 7 dla  
złożenia łożeczka LEWOSTRONNEGO

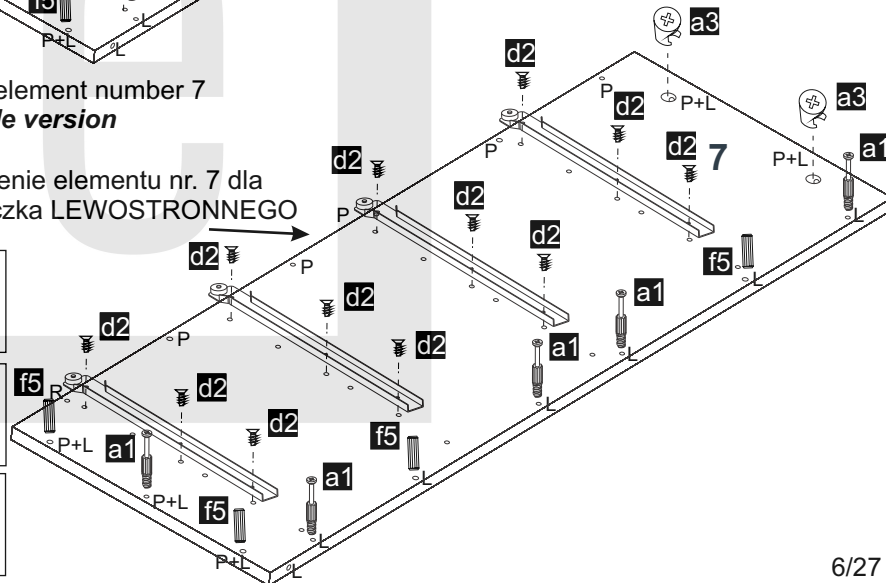
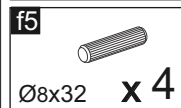
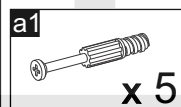

6

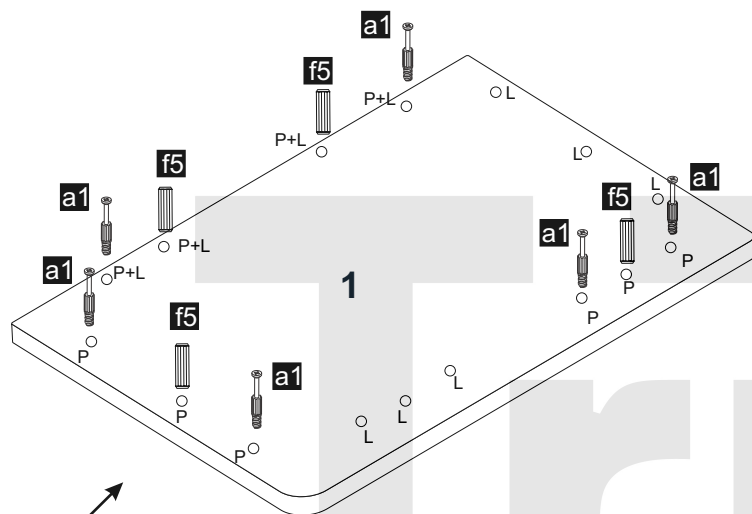
**UWAGA:**

Widok uzbrojenie elementu nr. 1 dla  
zmontowania łożeczka PRAWOSTRONNEGO

Element number 1 fitted for the *right side version*.

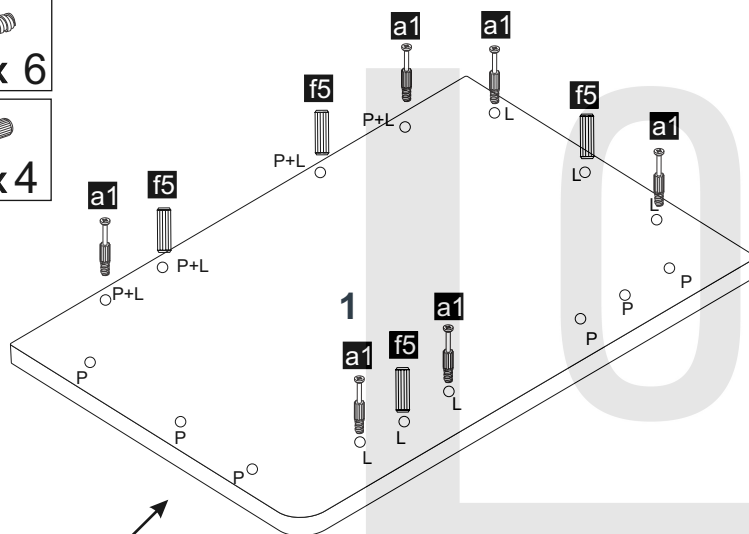
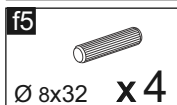
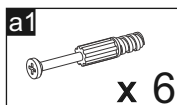
**UWAGA:**

Widok uzbrojenie elementu nr. 1 dla  
zmontowania łożeczka LEWOSTRONNEGO

Element number 1 fitted for the *left side version*.

7

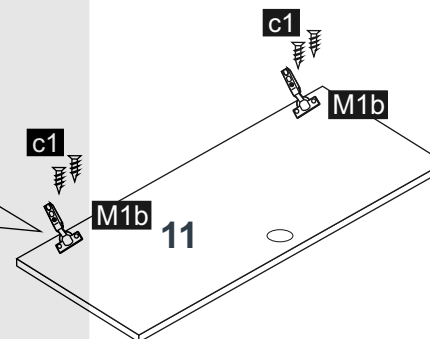
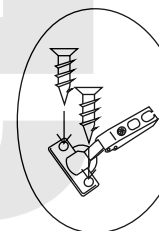
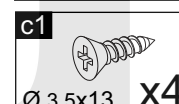
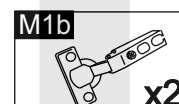
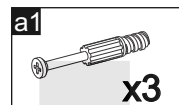
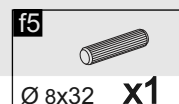
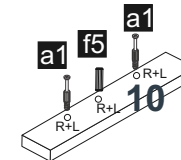
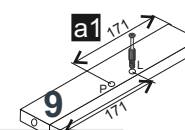
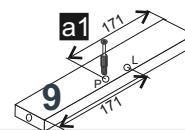

8

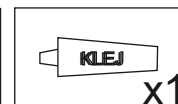
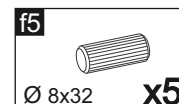
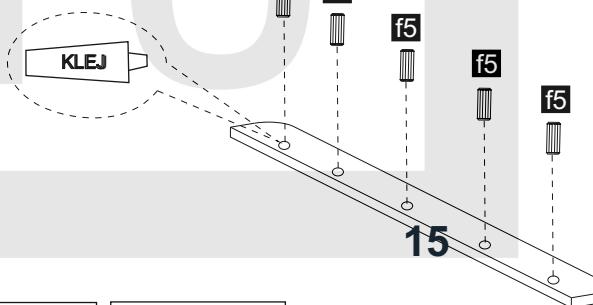

7/24

8/27

9

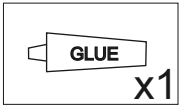
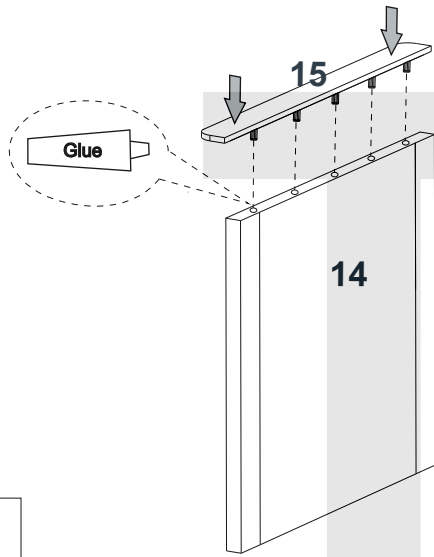

10

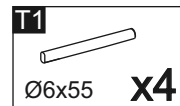
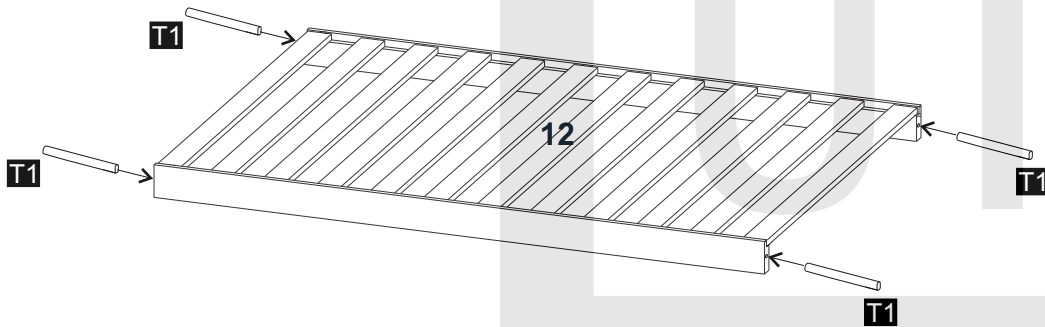

11

**PRAWOSTRONNE**  
*Right side version*

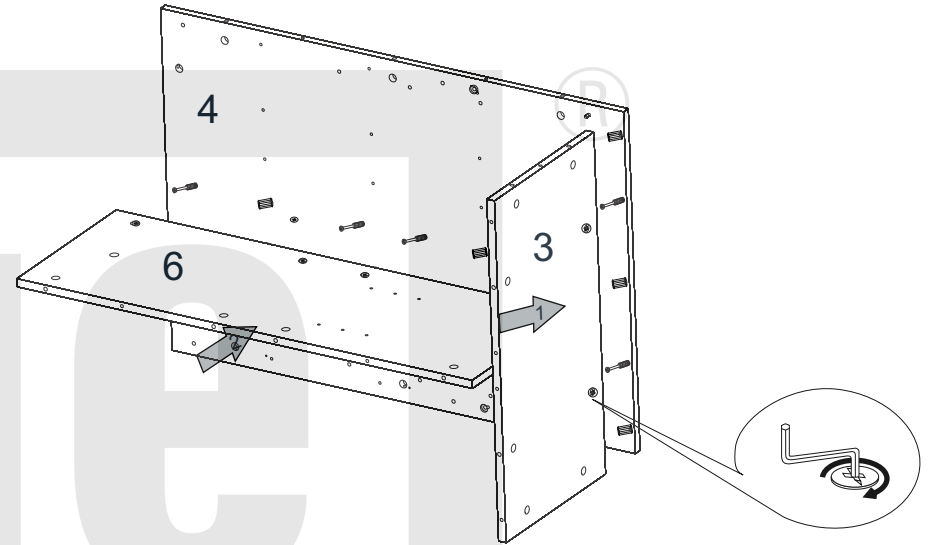

**LEWOSTRONNE**  
*Left side version*

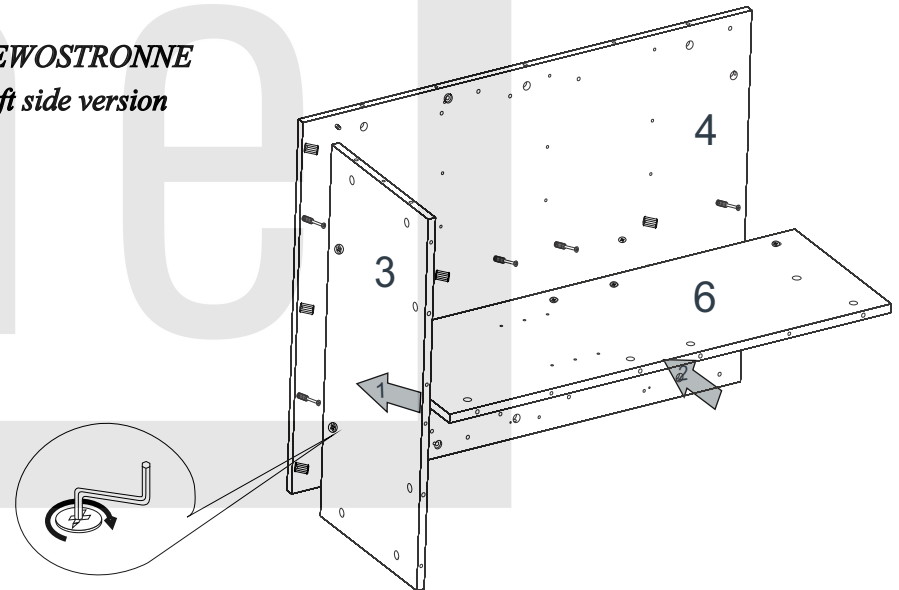

**12** *PRAWOSTRONNE*  
*Right side version*

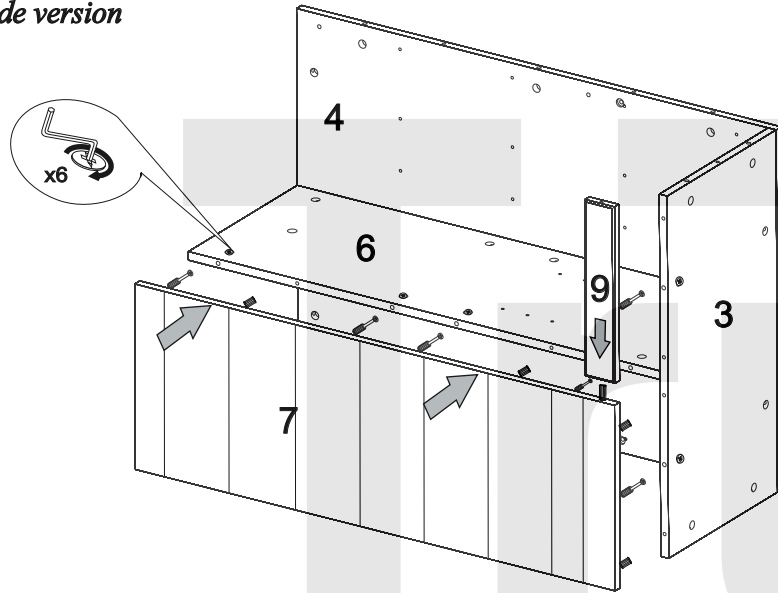

**13** *PRAWOSTRONNE*  
*Right side version*

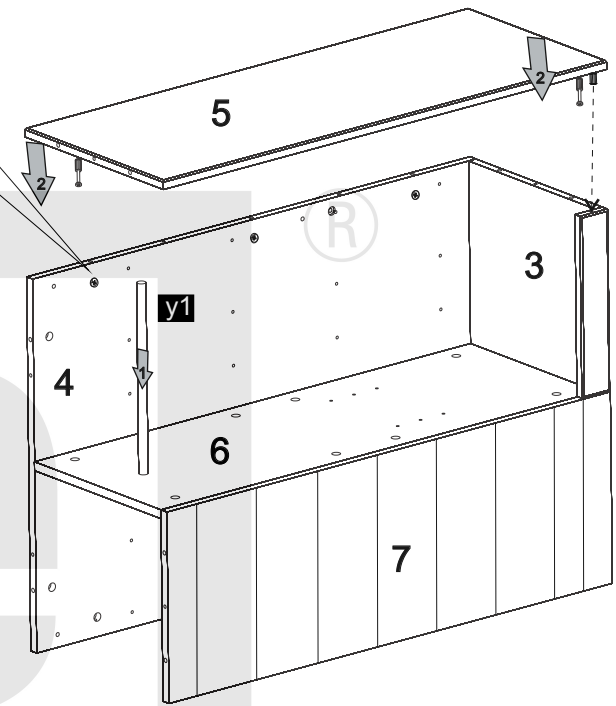
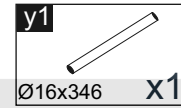

**12** *LEWOSTRONNE*  
*Left side version*

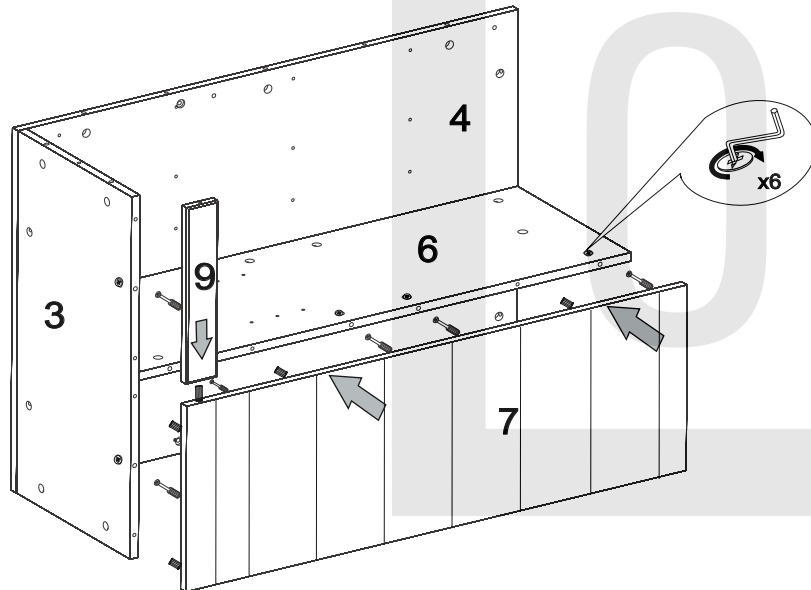

**13**  
*LEWOSTRONNE*  
*Left side version*

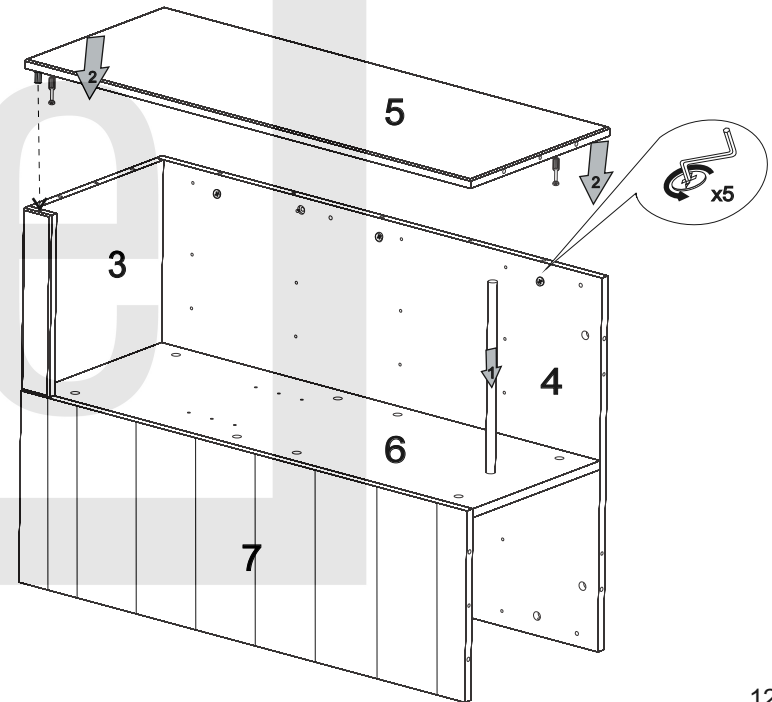

**14** *PRAWOSTRONNE*  
*Right side version*

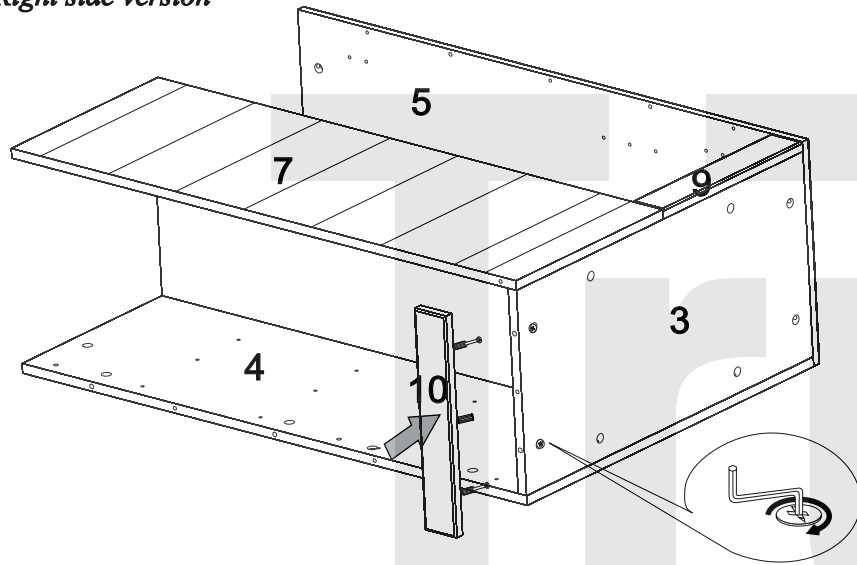

**15** *PRAWOSTRONNE*  
*Right side version*

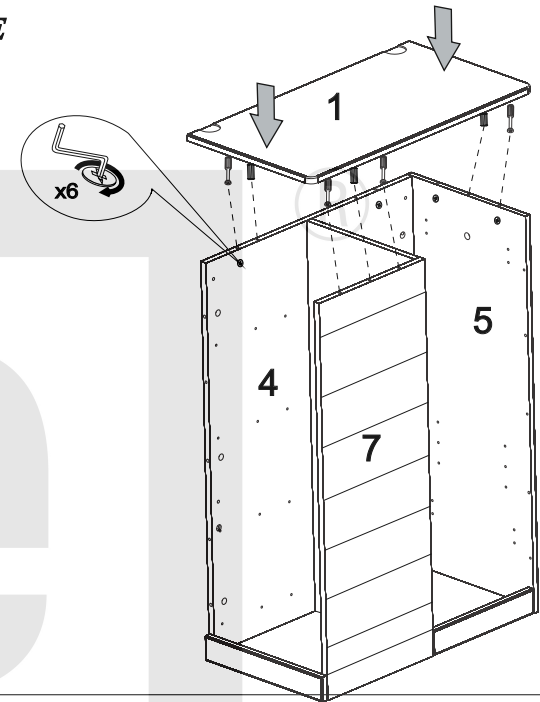

**14** *LEWOSTRONNE*  
*Left side version*

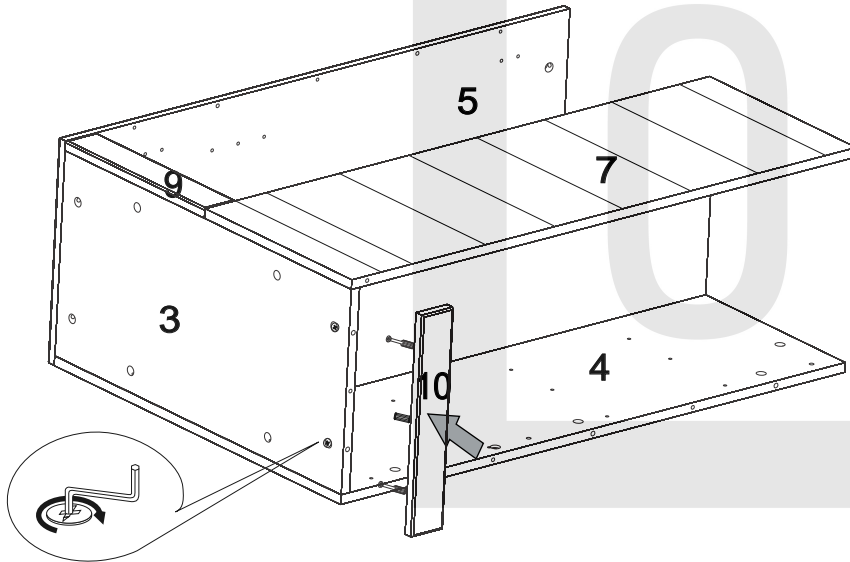

**15** *LEWOSTRONNE*  
*Left side version*

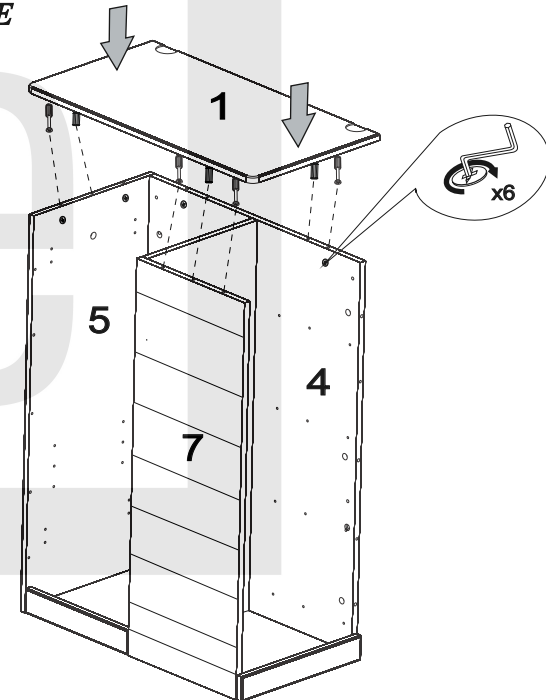

16

- d2**  
Ø6,3x10 x8
- d10**  
Ø 6,3x16 x8

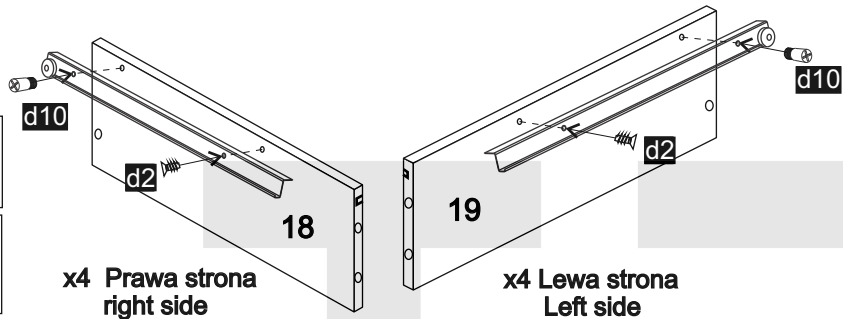

19

- a3**  
Ø 15x12 x8
- b1**  
Ø 7x50 x4
- f5**  
Ø8x32 x4

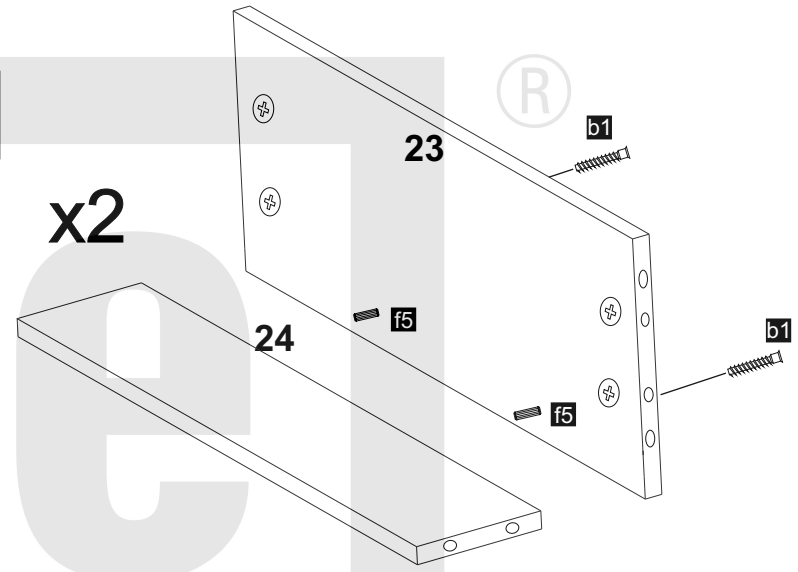

17

- b1**  
Ø7x50 x16
- a1**  
x16
- a3**  
Ø15x12 x16
- f5**  
Ø8x32 x16

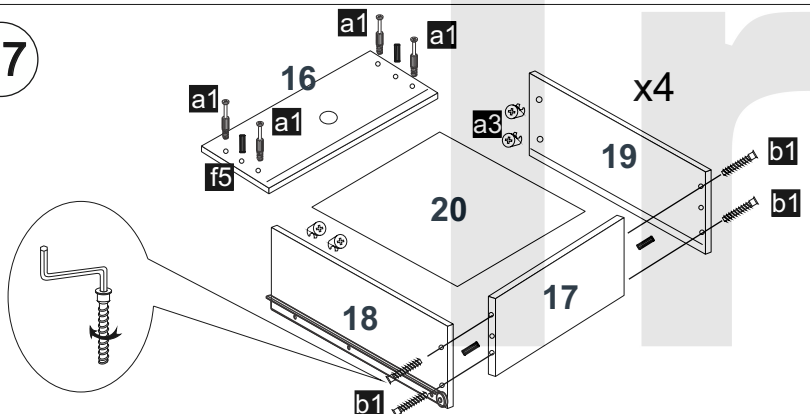

20

- c8**  
Ø 4x16 x8
- k8**  
x4
- a1**  
x12
- a3**  
Ø15x12 x4
- f5**  
Ø8x32 x20

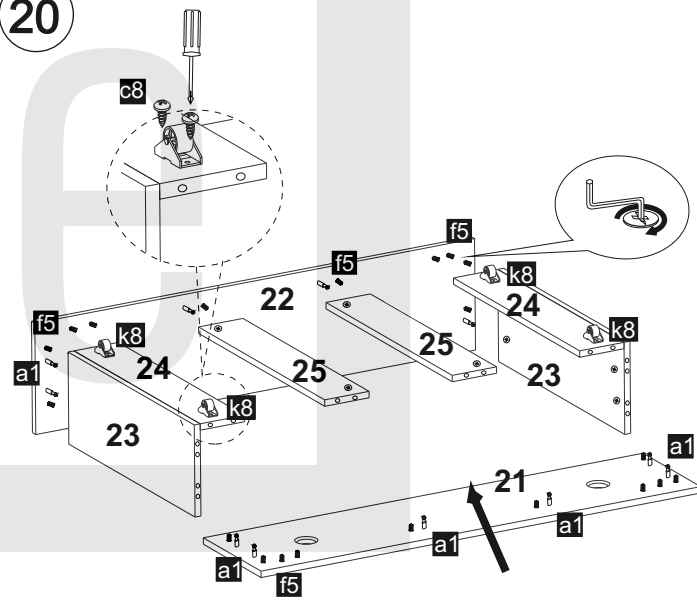

18

- c6**  
Ø3x20 x8

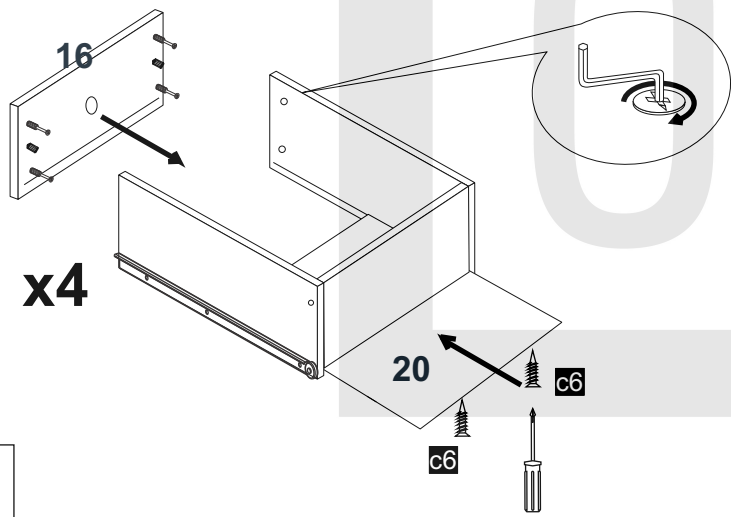



**21** PRAWOSTRONNE  
Right side version

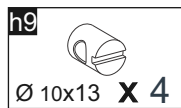
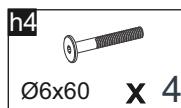
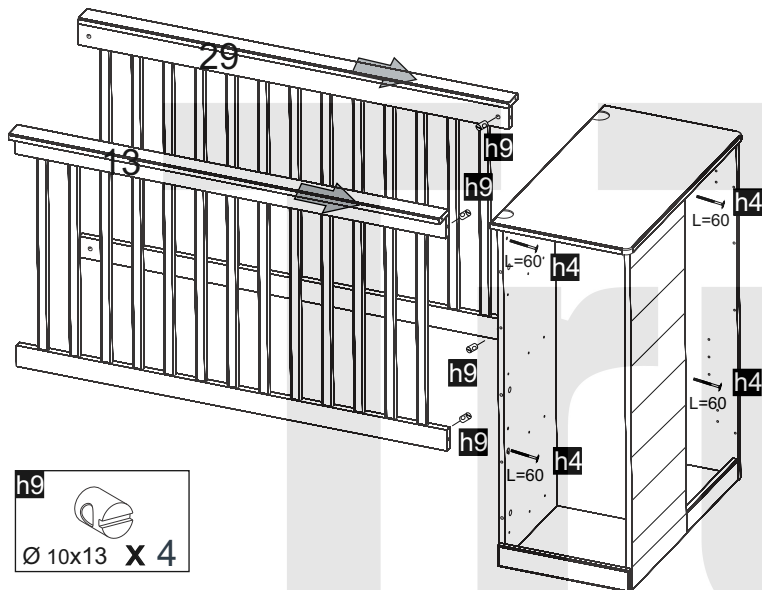

**22** PRAWOSTRONNE  
Right side version

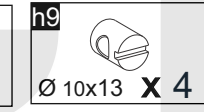
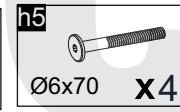
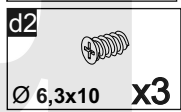
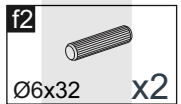
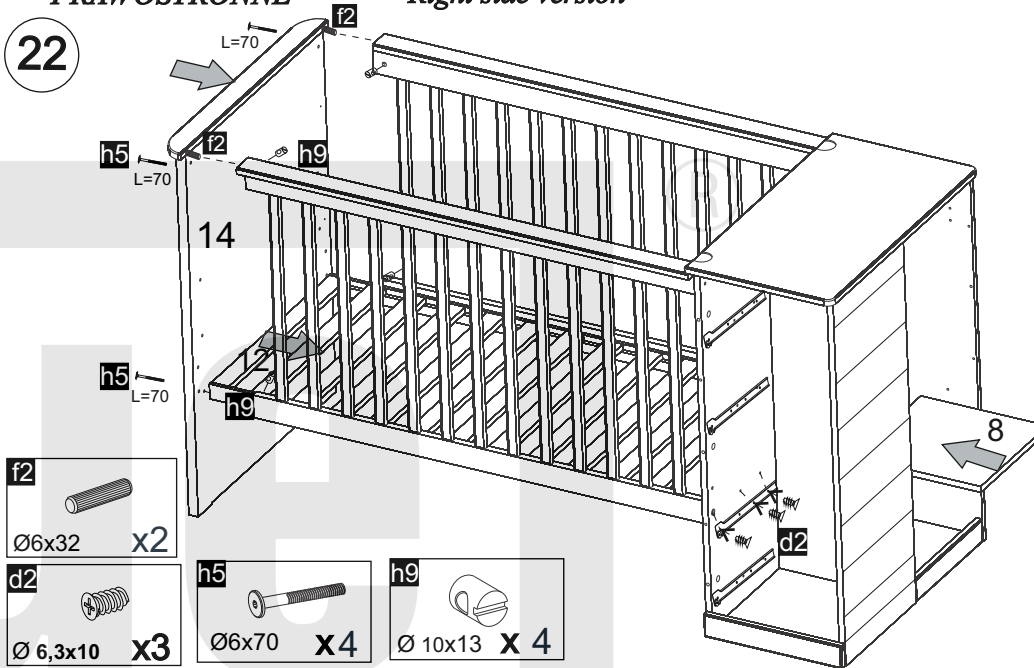

**21** LEWOSTRONNE  
Left side version

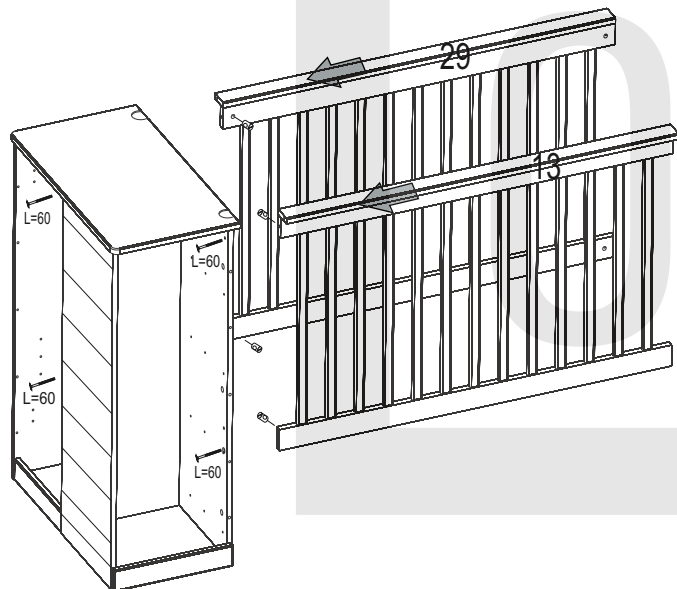

**22** LEWOSTRONNE  
Left side version

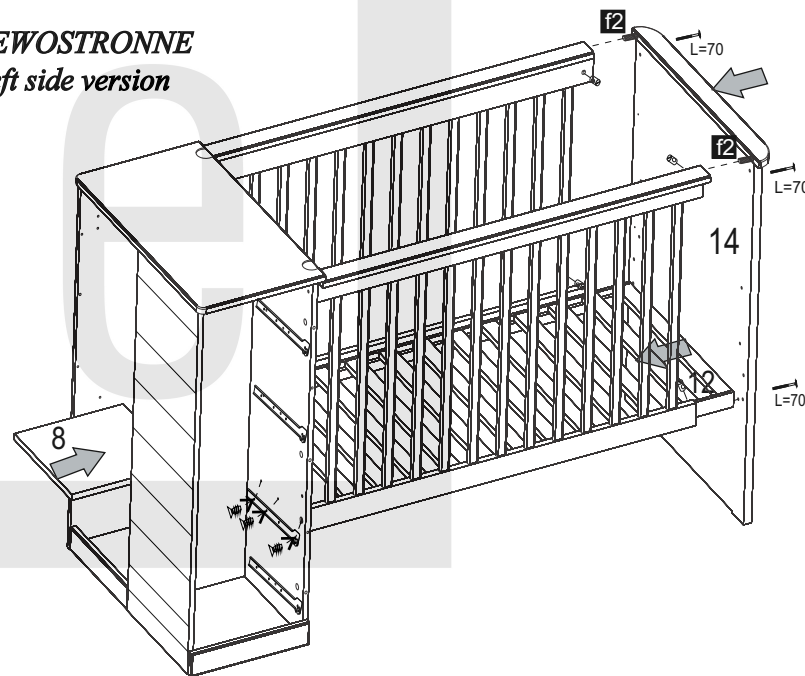

23

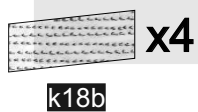
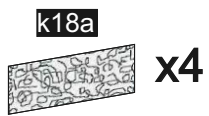
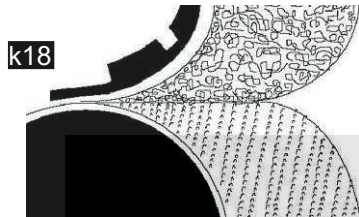
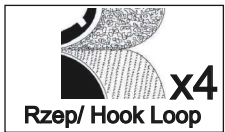

25

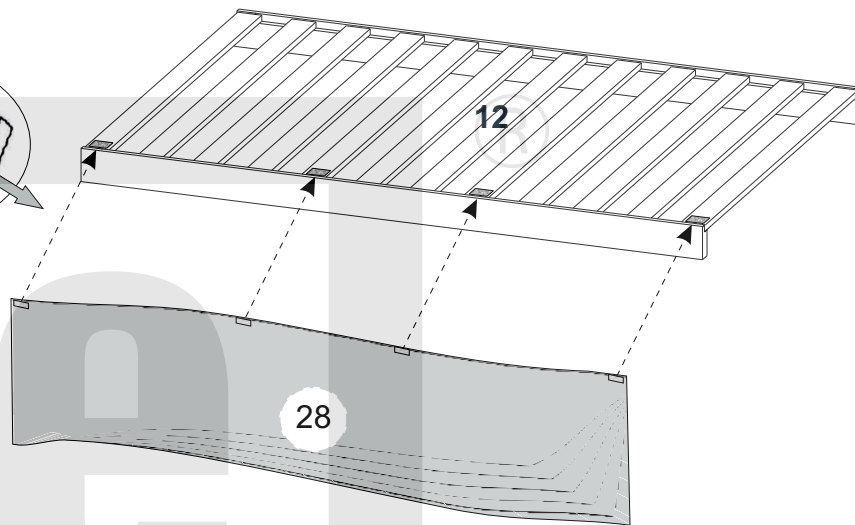
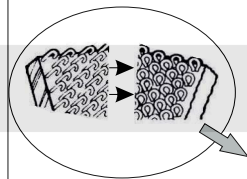

24

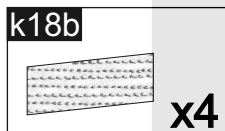

a)

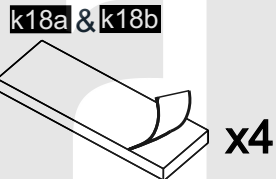

b)

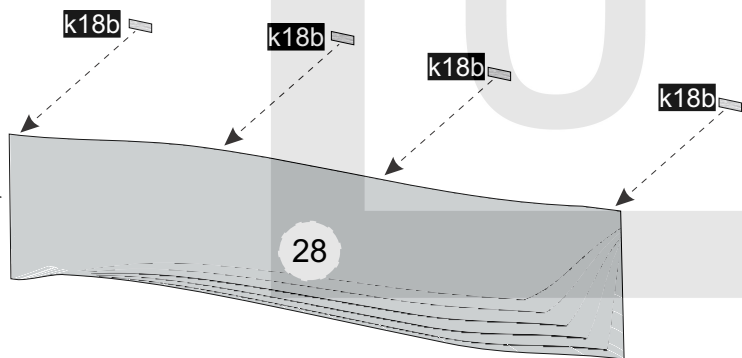
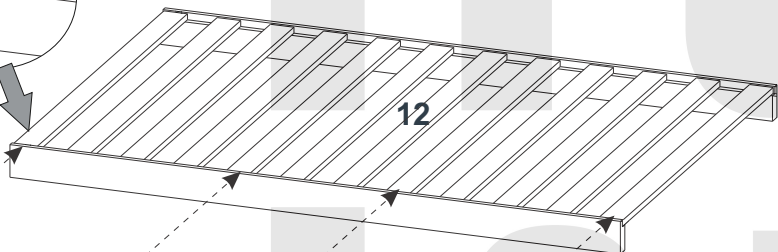
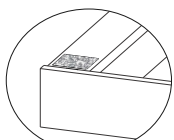

26

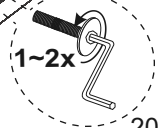
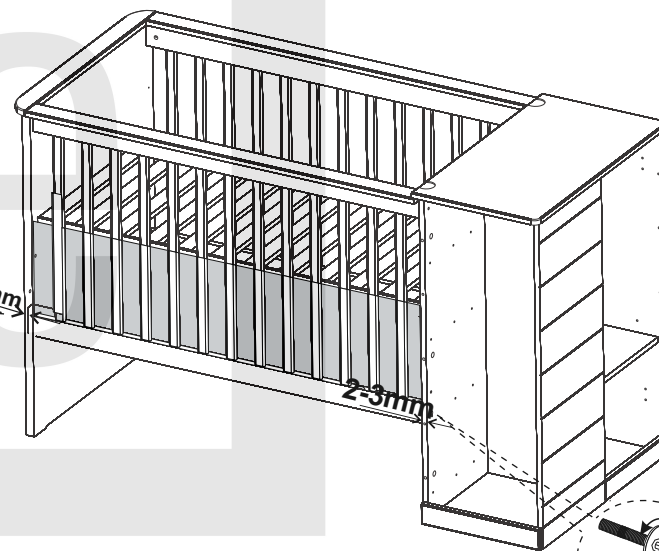
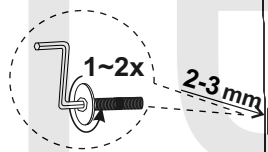

19/27

20/27

27

**PRAWOSTRONNE**

*Right side version*

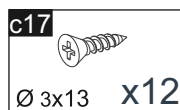
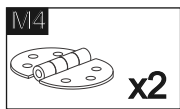
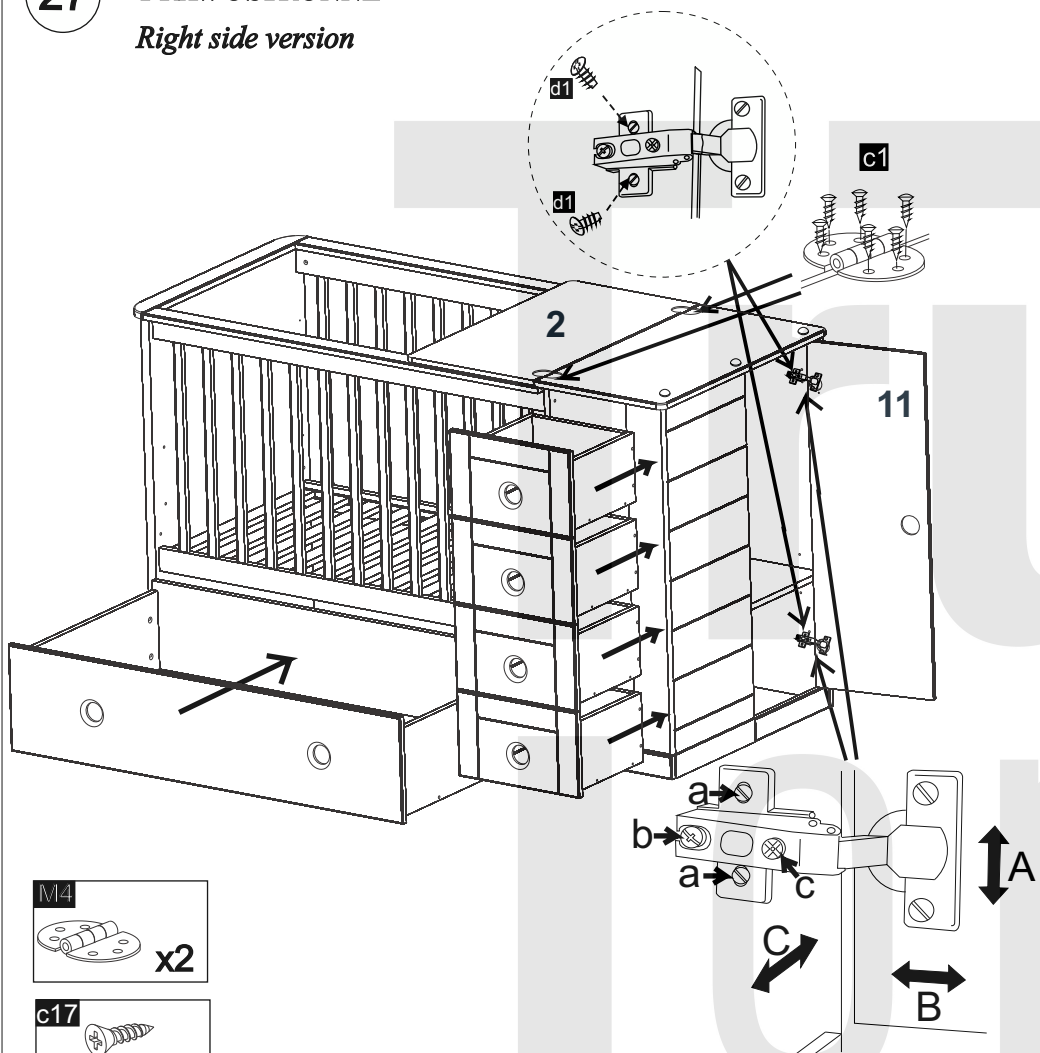

27

**LEWOSTRONNE**

*Left side version*

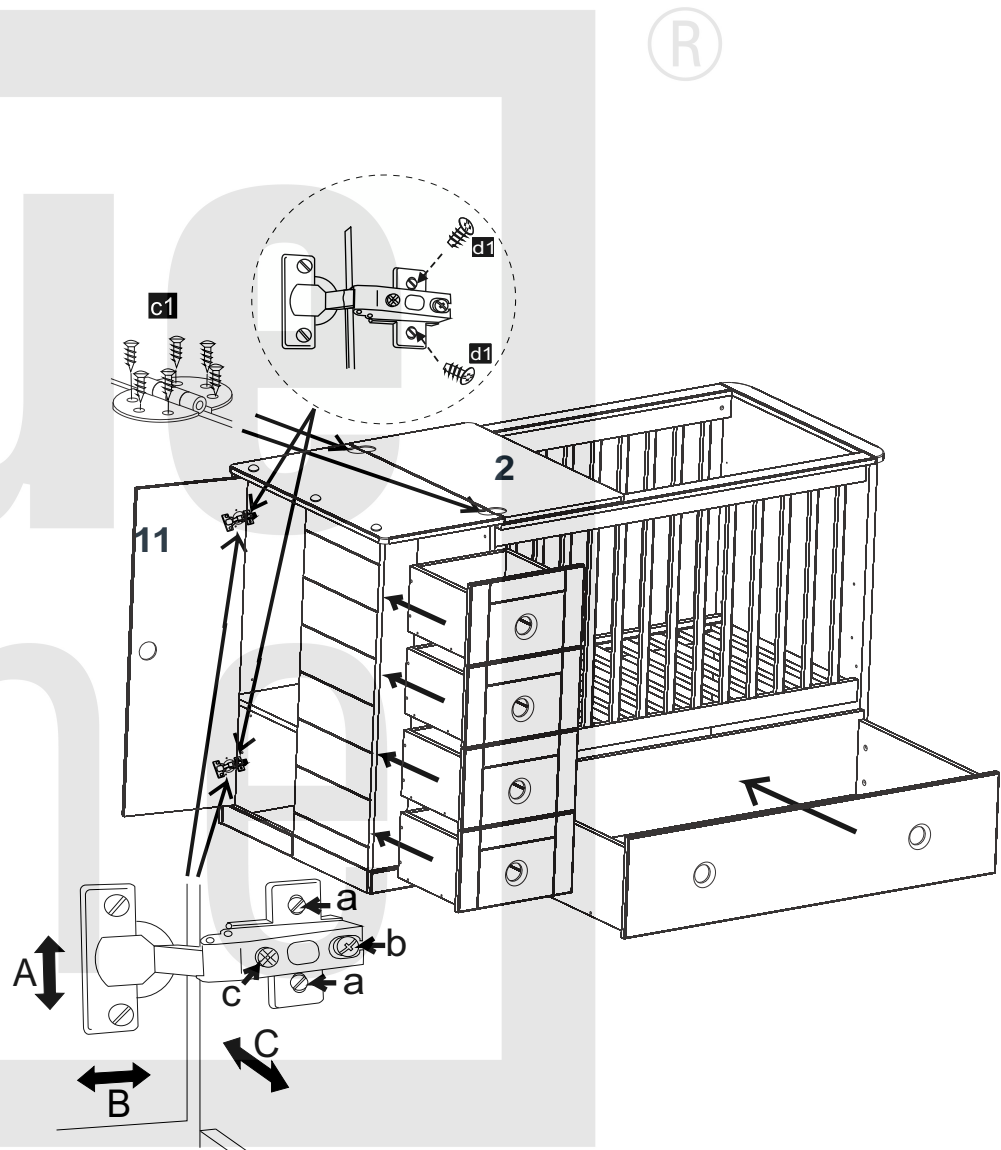

transformation

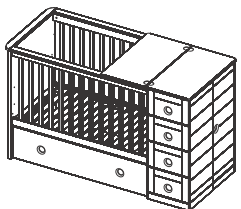

transformation

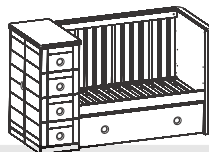
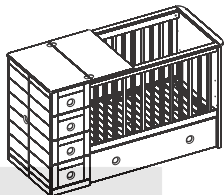
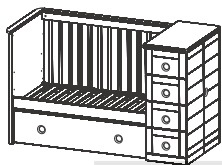

28

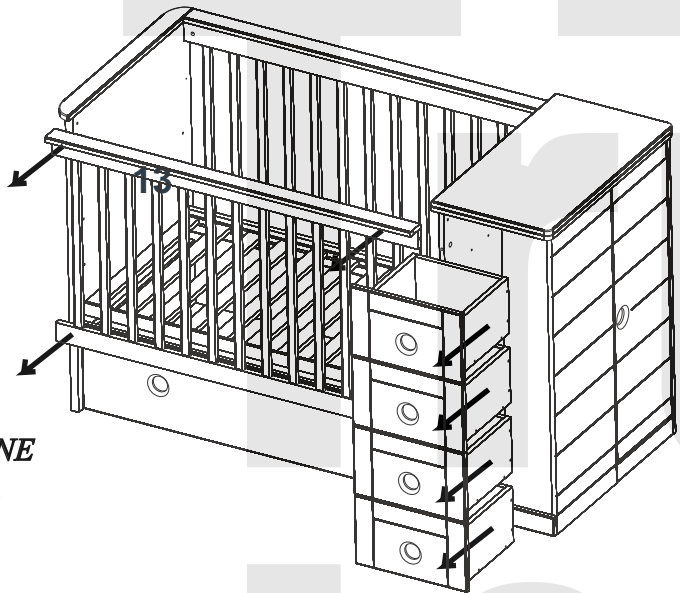

**PRAWOSTRONNE**  
*Right side version*

29

**PRAWOSTRONNE**  
*Right side version*

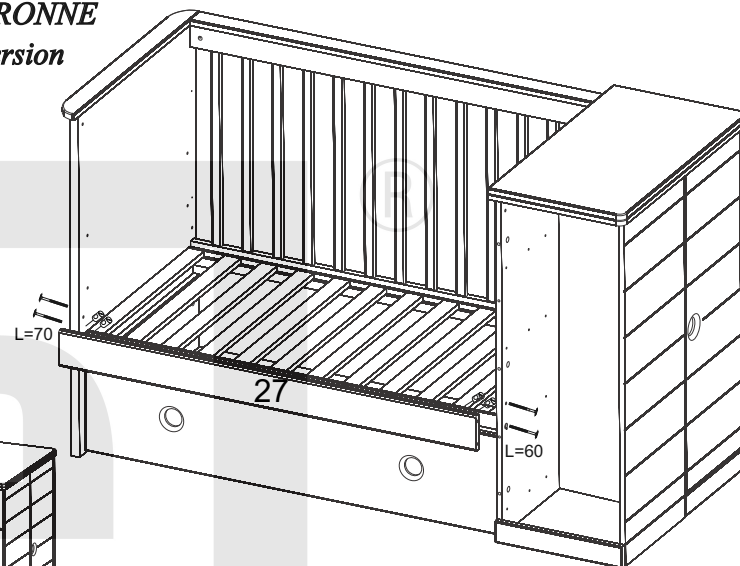
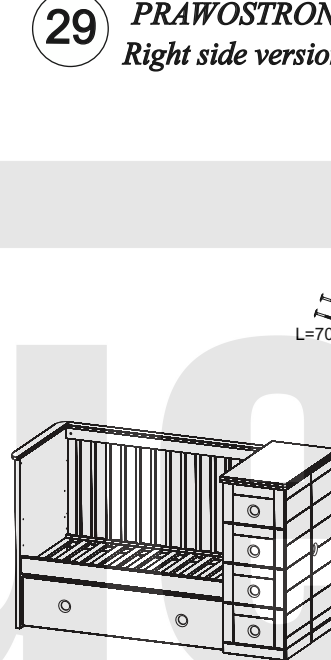

29

**LEWOSTRONNE** *Left side version*

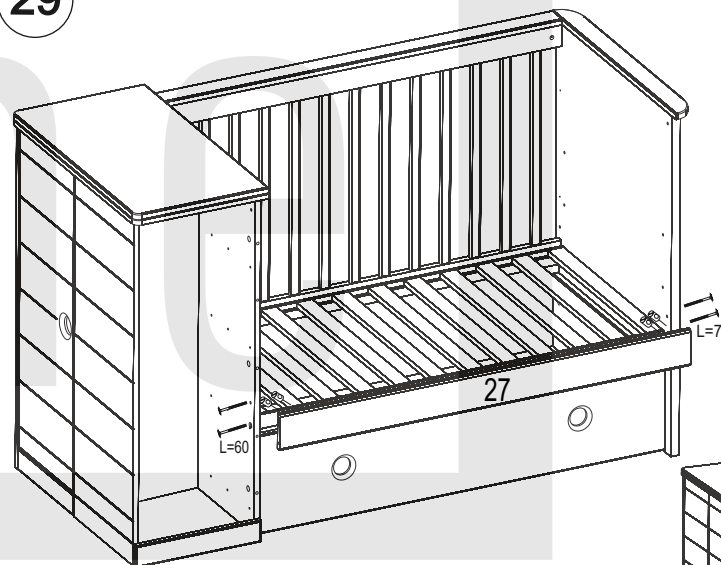

28

**LEWOSTRONNE**  
*Left side version*

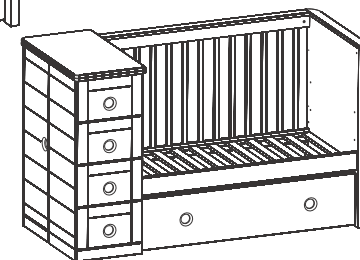
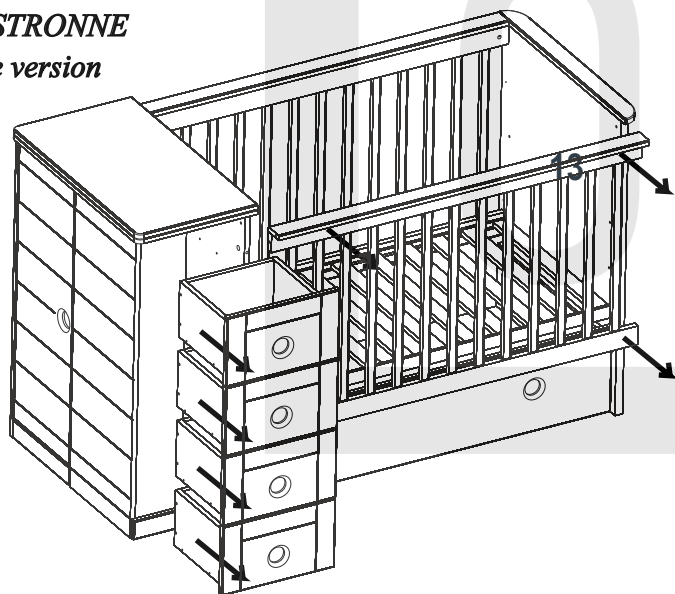

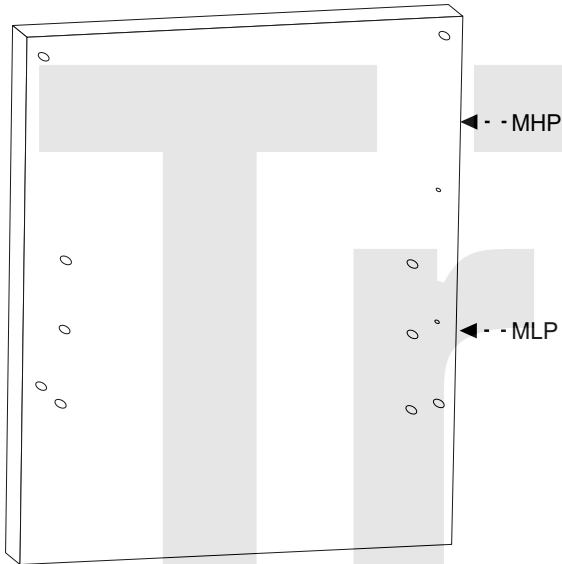

EN

MHP - Maximum height upper surface of the mattress in the highest position of the cot base

HP - The highest position of the cot base

MP - Middle position of the cot base

LP - The lowest position of the cot base

MLP - Maximum height upper surface of the mattress in the lowest position of the cot base

Covering material for the drawer 139/70 cm: 100% cotton

Installed to the bar sides of the cot only when the mattress base is on the middle or high position.  
Remove when transferred to the low position.

PL

MHP - Maksymalna wysokość górnej płaszczyzny materaca w najniższym położeniu dna łóżka

HP - Najwyższe położenie dna łóżka

MP - Średnie położenie dna łóżka

LP - Najniższe położenie dna łóżka

MLP - Maksymalna wysokość górnej płaszczyzny materaca w najniższym położeniu dna łóżka

Maskownica zawartości szuflady 139/70cm: 100% bawełna

Instalować do boków łóżeczka w przypadku gdy leżysko znajduje się w środkowym lub wyższym położeniu. Usunąć w przypadku obniżenia leżyska na najniższy poziom.

EN

## “IMPORTANT, READ CAREFULLY RETAIN FOR FUTURE REFERENCE”

1. The Lowest position is the safest, the base should always be used in that position as soon as the baby is old enough to sit up.
2. Do not leave anything in the cot or place the cot close to another product, which could provide a foothold or present a danger of suffocation or strangulation, e.g. strings, blind/curtain cords, etc.
3. In the cots with drop side If you leave your child unattended always check if the drop side is in the highest position.
4. In the cots with removable dowels, always remove three dowels when your child can crawl.
5. In the cots with drawers and removable dowels, after removing dowels, always remember that drawer should be closed.
6. Do not place your cot in the close proximity of an open fire and other sources of heat, such as radiators electric or gasfires.
7. The thickness of the mattress shall be such that the internal height (surface of the mattress to the upper edge of the cot frame) is at least 500 mm in the lowest position of the cot base and at least 200 mm in the highest position of the cot base.
8. The mattress should not be thicker than 100 mm.
9. The mattress should be no more than 30 mm shorter or narrower than the internal length or width of the cot.
10. All assembly fittings should be tightened properly and care should be taken to ensure that no screws are loose, a child could trap parts of the body, or clothing (e.g. ribbons, drawstrings, necklaces) this could pose a risk of strangulation.
11. Regularly check that all fittings and components of the cot are fully tightened and in working order.
12. Do not use the cot if any part is broken, torn or missing.
13. Should use only spare parts approved by the manufacturer.
14. Do not use more than one mattress.
15. To prevent injuries resulting from falling down, the cot should not be used after the baby is able to climb on the top of the cot or leave it.

### Cleaning and maintenance

1. Use generally available furniture cleaning detergents.
2. Do not use aggressive detergents and always read the detergent's usage instructions.
3. Do not use hard brushes or any other harsh materials that could streak the surface of the furniture.

## “WAŻNE! - UWAGA! NIE PRZECZYTAĆ ZACHOWAĆ DO PÓŹNIEJSZEGO STOSOWANIA”

1. Najbezpieczniejsze jest najniższe położenie dna leżyska, gdy dziecko zaczyna samodzielnie siadać należy używać tylko tego poziomu.
2. Należy nie pozostawiać wózków czegokolwiek, co mogłoby dziecku umożliwić wspięcie się w górę oraz rzeczy, które mogłyby spowodować uduszenie lub zadławienie.
3. Gdy pozostawi siedząco bez nadzoru wózek z opuszczonym bokiem, należy zawsze upewnić się czy opuszczany bok znajduje się w najwyższym położeniu.
4. Wózkach ze szczebliną wyjmowaną, szczebliny można wyciągnąć bok wózka, gdy dziecko już samodzielnie chodzi, przy czym zawsze należy wyjąć trzy szczebliny. Po wyciągnięciu wyjmowanych szczeblin, w przypadku stwierdzenia możliwości wyciągnięcia przez dziecko szprymy znajdującej się w ramie jednego z boków, należy je zdemontować i pozostawić w miejscu niedostępnym dla dziecka.
5. Wózkach wyposażonych w szufladę wyjmowane szczebliny, po wyjęciu szczeblin należy pamiętać, aby szuflada była w pozycji zamkniętej.
6. Należy nie stawiać łóżka w pobliżu otwartego ognia albo innych silnych źródeł ciepła, takich jak: promienniki elektryczne, gazowe.
7. Wewnętrzna wysokość (mierzona od górnej płaszczyzny materaca do górnej krawędzi boku wózka) powinna wynosić co najmniej 500mm. w najniższym położeniu dna, 200mm w najwyższym położeniu dna wózka.
8. Wysokość materaca nie powinna przekraczać 100mm.
9. Długość szerokość materaca dobrać tak aby szczelina między materacem a bokiem i przodem wózka nie przekraczała 30mm.
10. Wszystkie okucia powinny być dobrze dokręcone, tak aby uniemożliwić zahaczenie się cięcia lub elementu odzieży dziecka (np. sznurki, naszyjniki lub tasiemki od smoczków), co mogłoby spowodować niebezpieczeństwo uduszenia.
11. W trakcie użytkowania wózka należy okresowo sprawdzać, czy nie nastąpiło poluzowanie połączeń śrubowych. Jeżeli tak, śruby należy dokręcić do wystąpienia oporu.
12. Nie używać wózka gdy jakaś jego część jest uszkodzona lub jej brakuje.
13. Należy stosować tylko części zamienne zatwierdzone przez producenta.
14. Ostrzeżenie! Nie używać wózka więcej niż jednego materaca.
15. Aby zapobiec obrażeniom dziecka wskutek upadku, wózek nie powinien być dłużej użytkowany, jeżeli dziecko potrafi się wspiąć na wózek.

### Czyszczenie i pielęgnacja

1. Należy używać ogólnie dostępnych środków ochrony mebli drewnianych.
2. Nie stosować agresywnych środków czyszczących i zawsze zapoznać się z uwagami producenta tego preparatu.
3. Nie stosować twardych szczotek czy szorstkich ścierek mogących porysować powierzchnie mebli

